

CH
Cooper & Hunter

SERIES

SUPREME

VARIOUS DESIGN SOLUTIONS

Supreme series are using eco-friendly refrigerant R32 and operating in wide range of outdoor temperatures it all allows to meet all needs of indoor climate. Winter operation is up to -30°C, meanwhile summer operation is up to +54°C.

In addition to strong operational data, Supreme series has various colour design types of indoor units that combines to different interior.



Series SUPREME

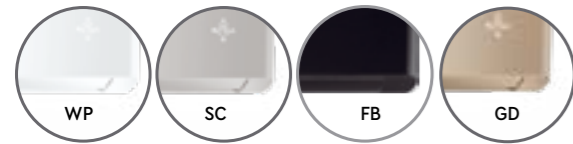

FUNCTION

HEALTH					COMFORT MANAGEMENT									
Mode SLEEP	Technology CH 7-SKY	ECO-FRESH	CH SMART-ION Filter	Self-clean	Locking the remote control	Timer	LED display	Turbo mode	Multi speed fan	SWING mode	Dehumidification mode	Wi-Fi	I FEEL	
INTELLIGENT CONTROL				TECHNOLOGICAL						ENERGY EFFICIENCY				
Anti Freeze protection	Auto restart	Self diagnostics	Display backlight	Wired controller connection	R32 Refrigerant	Silent mode	Auto protection	Function 8°C	Technology I-Action	Coating BLUE-FIN	Two-Stage Compressor	Warm start	Energy Efficiency	6 generation

CONTROLS AND ACCESSORIES (OPTIONAL)



Wired Controller XK76



Wired Controller CES0-24/E



Wired Controller CES2-24/F

MODEL			CH-S09FTXAM2S-***	CH-S12FTXAM2S-***	CH-S18FTXAM2S-***	CH-S24FTXAM2S-***
Capacity	Cooling	kW	2.70 (0.70-5.00)	3.53 (0.85-5.00)	5.30 (1.20-7.20)	7.03 (2.00-9.00)
	Heating	kW	3.50 (0.70-5.50)	4.20 (0.88-7.20)	6.20 (1.20-9.20)	7.03 (2.00-9.50)
Power consumption	Cooling	kW	0.55 (0.08-1.80)	0.84 (0.06-1.90)	1.18 (0.35-2.50)	1.85 (0.45-3.70)
	Heating	kW	0.75 (0.13-2.40)	0.95 (0.13-2.60)	1.45 (0.35-3.30)	1.75 (0.38-3.80)
Energy efficiency	Cooling (SEER*)	kW/kW	8.5 (A+++)	8.5 (A+++)	7.5 (A++)	6.5 (A++)
	Heating (SCOP**)	kW/kW	5.7 (A+++)	5.7 (A+++)	5.1 (A+++)	5.3 (A+++)

* SEER - seasonal coefficient of system cooling capacity.
 ** SCOP - seasonal coefficient of system heating capacity.
 *** The indoor unit is available in four colors: white (WP), black with silver (BL), silver metallic (SC), champagne (GD)

INDOOR UNIT		CH-S09FTXAM2S-***	CH-S12FTXAM2S-***	CH-S18FTXAM2S-***	CH-S24FTXAM2S-***
Air productivity	m³/h	800/730/680/630/580/450/350/250	800/730/680/630/580/450/350/250	1200/1150/1050/950/850/780/600	1250/1100/950/850/800/750/650
Sound pressure level	dB (A)	44/43/38/36/31/24/22/18	44/43/38/36/31/24/22/20	46/44/42/39/36/34/32	50/46/43/41/39/37/35/27
Dehumidification	l/h	0.8	1.4	1.8	2.0
Weight	kg	13	13.5	16.5	16.5

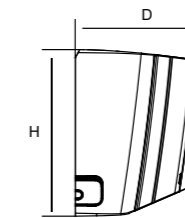
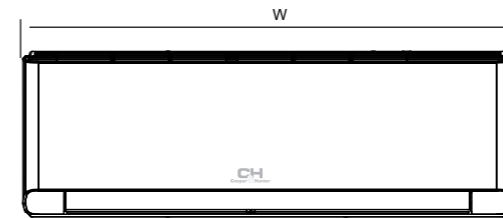

MODEL	W (mm)	H (mm)	D (mm)
CH-S09FTXAM2S-***	996	301	225
CH-S12FTXAM2S-***	996	301	225
CH-S18FTXAM2S-***	1101	327	249
CH-S24FTXAM2S-***	1101	327	249

OUTDOOR UNIT		CH-S09FTXAM2S-***	CH-S12FTXAM2S-***	CH-S18FTXAM2S-***	CH-S24FTXAM2S-***
Sound pressure level	dB (A)	53	54	56	58
Compressor type		Rotary			
Refrigerant type		R-32			
Temperature range for cooling	°C	-18 ... +54			
Temperature range for heating	°C	-30 ... +24			
Power supply		~220-240V/50Hz/1 Ph			
Weight	kg	44.5	45.5	62.5	65
Gas charging volume	kg	1.0	1	1.5	2.0
Liquid pipeline diameter	mm/inch	6.35/ 1/4"	6.35/ 1/4"	6.35/1/4"	6.35/1/4"
Gas pipeline diameter	mm/inch	9.52/3/8"	9.52/3/8"	15.88/5/8"	15.88/5/8"
Maximum pipeline level difference	m	10	10	20	30
Pipeline maximum length	m	15	20	40	50

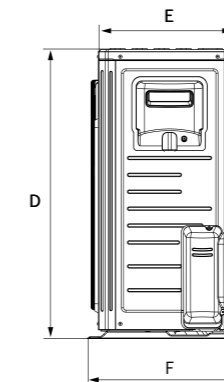
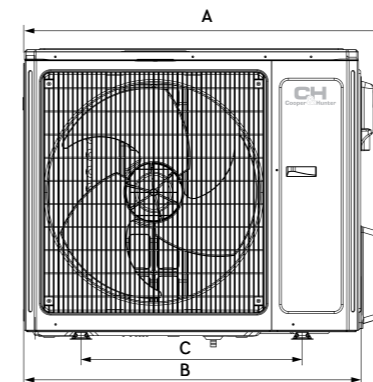

MODEL	A (mm)	B (mm)	C (mm)	D (mm)	E (mm)	F (mm)
CH-S09FTXAM2S-***	899	838	550	596	303	378
CH-S12FTXAM2S-***	899	838	550	596	303	378
CH-S18FTXAM2S-***	1000	920	610	790	370	427
CH-S24FTXAM2S-***	1000	920	610	790	370	427