

# Installation Manual

---



Air to Water Heat Pumps



CH-HP08UIMPRM CH-HP12UIMPRM CH-HP20UIMPRM CH-HP24UIMPRM



[www.cooperandhunter.com](http://www.cooperandhunter.com)

# Content

1. Preface. ....	1
2. Safety Instructions. . . . .	2
3. Features. ....	3
4. Unit Dimension (mm). ....	5
5. Installation Diagram. ....	7
6. Handling & Installation. . . . .	8
7. Maintenance. . . . .	11
8. Parameters. ....	13
9. Wiring Diagram. . . . .	14
10. Display Operation Guide. ....	17
11. Failure List & Troubleshooting. . . . .	26

## 1. Preface

In order to provide customers with high-quality, strong reliable and good versatile products, this heat pump is manufactured by strict design and manufacture standards.

This manual includes all the necessary information about installation, debugging and maintenance. Please read the manual carefully before you start or maintain the unit.

The manufacturer of this product will not be held responsible if someone is injured or the unit is damaged, as a result of improper installation, debugging, unnecessary maintenance which is not in line with this manual.

The unit must be installed by qualified personnel.

It is vital that the below instructions are adhered to at all times to keep the warranty.

—The unit can only be turned on or repaired by a qualified installer or an authorized dealer.

—Maintenance and operation must be carried out according to the recommended time and frequency, as stated in this manual.

—Use standard spare parts only.



Failure to comply with these recommendations will invalidate the warranty.

Inverter air to water heat pump is a kind of high efficiency, energy-saving and environment-friendly equipment, which is mainly used for house heating/cooling and hot water. It can work with indoor units such as fan coils, radiators, or floor heating, to provide heating or hot water. One heat pump can work with several indoor units.



## 2. Safety Instructions

To prevent the users and maintainers from the harm of this unit, and avoid damage on the unit or other property, and use the heat pump properly, please read this manual carefully and understand the following information correctly.



### Mark Notes



Mark	Meaning
 WARNING	A wrong operation may lead to death or grievous injury on people.
 ATTENTION	A wrong operation may lead to harm on people or loss of material.



### Icon Notes

Icon	Meaning
	Prohibition. What is prohibited will be nearby this icon.
	Compulsory implement. The listed action need to be taken.
	ATTENTION (include WARNING) Please pay attention to what is indicated.

### Warning

Installation	Meaning
 Professional installer is required.	The heat pump must be installed by qualified personals, to avoid improper installation which may lead to water leakage, electrical shock or fire.
 Earthing is required.	Please make sure that the unit and power connection have good earthing, otherwise may cause electrical shock.



Operation	Meaning
 PROHIBITION	DO NOT put fingers or others into the fans and evaporator of the unit, otherwise harm may occur.
 Shut off the power.	When there is something wrong or strange smell, the power supply needs to be shut off to stop the unit. Continue running may cause short circuit or fire.





Move and Repair	Meaning
 Entrust	When the heat pump needs to be moved or installed again, please entrust dealer or qualified person to carry it out. Improper installation will lead to water leakage, electrical shock, injury or fire.
 Entrust	It is prohibited to repair the unit by the user himself, otherwise electrical shock or fire may occur.
 Prohibit	



The appliance shall be stored in a room without continuously operating ignition sources (for example: open flames, an operating gas appliance or an operating electric heater.)

## ATTENTION

Installation	Meaning
 Installation Place	The unit CANNOT be installed near the flammable gas. Once there is any leakage of the gas, fire may occur.
 Fix the unit.	Make sure that the basement of the heat pump is strong enough, to avoid any decline or fall down of the unit
 Need circuit breaker.	Make sure that there is circuit breaker for the unit, lack of circuit breaker may lead to electrical shock or fire.

Operation	Meaning
 Check the installation basement.	Please check the installation basement regularly (one month), to avoid any decline or damage on the basement, which may hurt people or damage the unit.
 Switch off the power.	Please switch off the power when cleaning or maintenance.
 Prohibition	It is prohibited to use copper or iron as fuse. The right fuse must be fixed by electrician for the heat pump.
 Prohibition	It is prohibited to spray the flammable gas to the heat pump, as it may cause fire.

### 3. Features

With new technology of DC Inverter EVI, Series can be used in extremely cold area for heating/cooling, hot water. The Series is featured as follows.

#### 3.1. DC Inverter EVI Heat Pump Technology

##### a. Ruking Driver Board

Ruking driver board controls the compressor running precisely basing on water temperature and air temperature. And it can work with wide voltage of 456V at maximum.

##### b. Panasonic Inverter Compressor

Panasonic inverter EVI compressor is adopted for the units to ensure high stability.

##### c. DC Fan Motor

DC fan motor with adjustable speed ensures the units' silent running. This makes the units work more efficiently at different conditions.

#### 3.2. A+++ Energy Level

DC inverter technology enables the heat pump to adjust its frequency from 30Hz - 90Hz according to real heating requirement. With this technology, Series achieve an energy level of A+++ according to ErP directive.

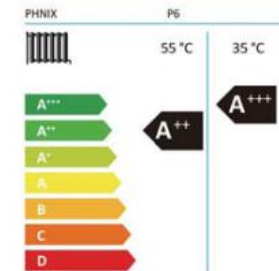

#### 3.3. Certification Guarant-junctiond

To meet the European market requirement, the series has achieved several certifications such as CE, ErP, MCS.



### 3.4. R32 Low GWP Gas

Compared with R410A refrigerant heat pumps, Series with R32 gas have a GWP of only one-third. It is an environment-friendly choice for reducing CO2 emission. Meanwhile, R32 heat pump needs 30% less amount than R410A heat pump.



### 3.5. Low Noise of 37dB(A)

With a new internal noise reducing design, Series can realize the lowest noise running of 37dB(A) when testing at 1 meter, so as to provide a silent living environment for users.

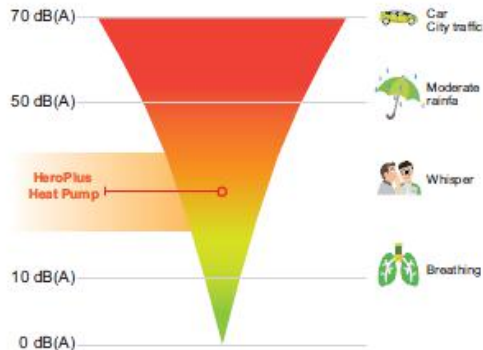

### 3.6. 5-inch Touch Display

5-inch display has many powerful functions, such as water temperature curve, easy timing, one-key mute, and mute timer.



### 3.7. APP & IOT

Simplify your life with WarmLink. Via connection by Wi-Fi or 4G, you can take full control of your heat pump from anywhere in your home or office with a single app on your smartphone.

Besides, has a central platform, which effectively saves the cost for manpower during the after-sales service period. The fault report button allows a direct error reporting channel to the local service provider. When an error has been reported, the service provider can see the error information of the target heat pump from the background system, and contact users immediately to offer help.

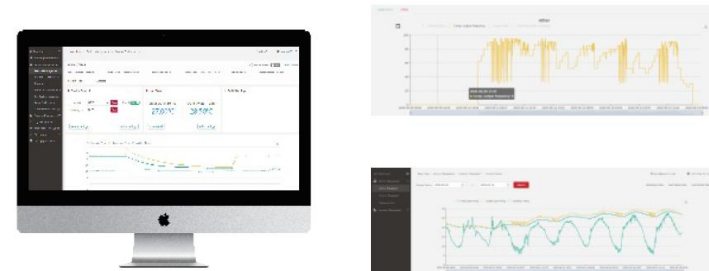

#### 4. Unit Dimension (mm)

##### 4.1. Models: CH-HP08UIMPRM

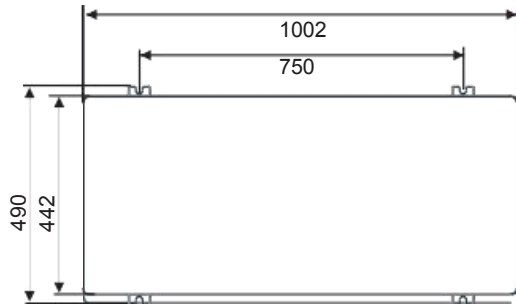
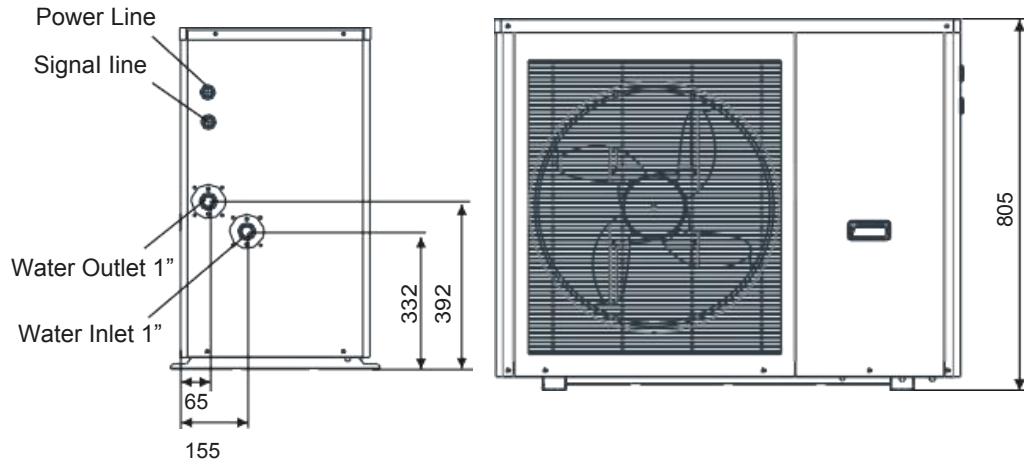

##### 4.2. Models: CH-HP12UIMPRM

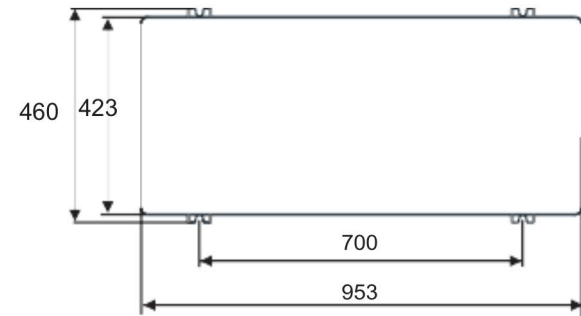
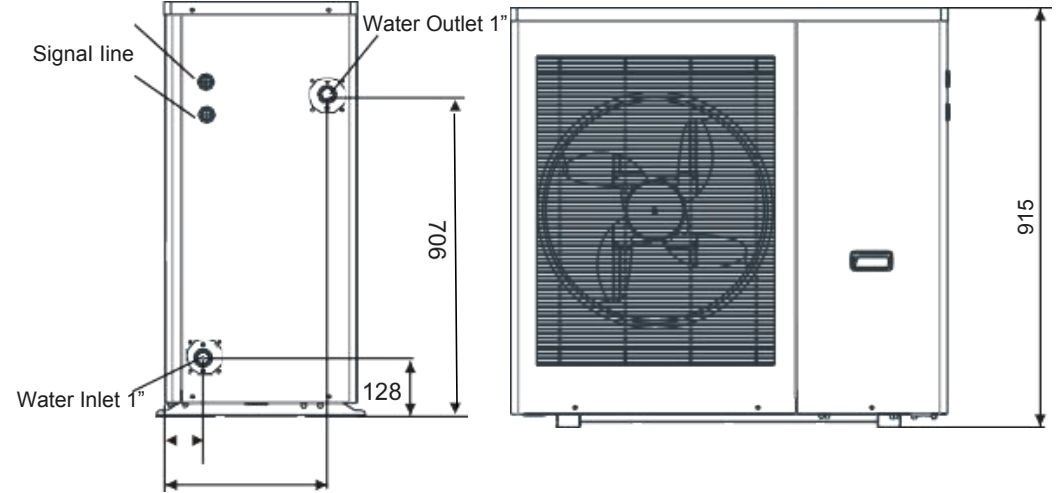

**4.3. Models: CH-HP20UIMPRM**

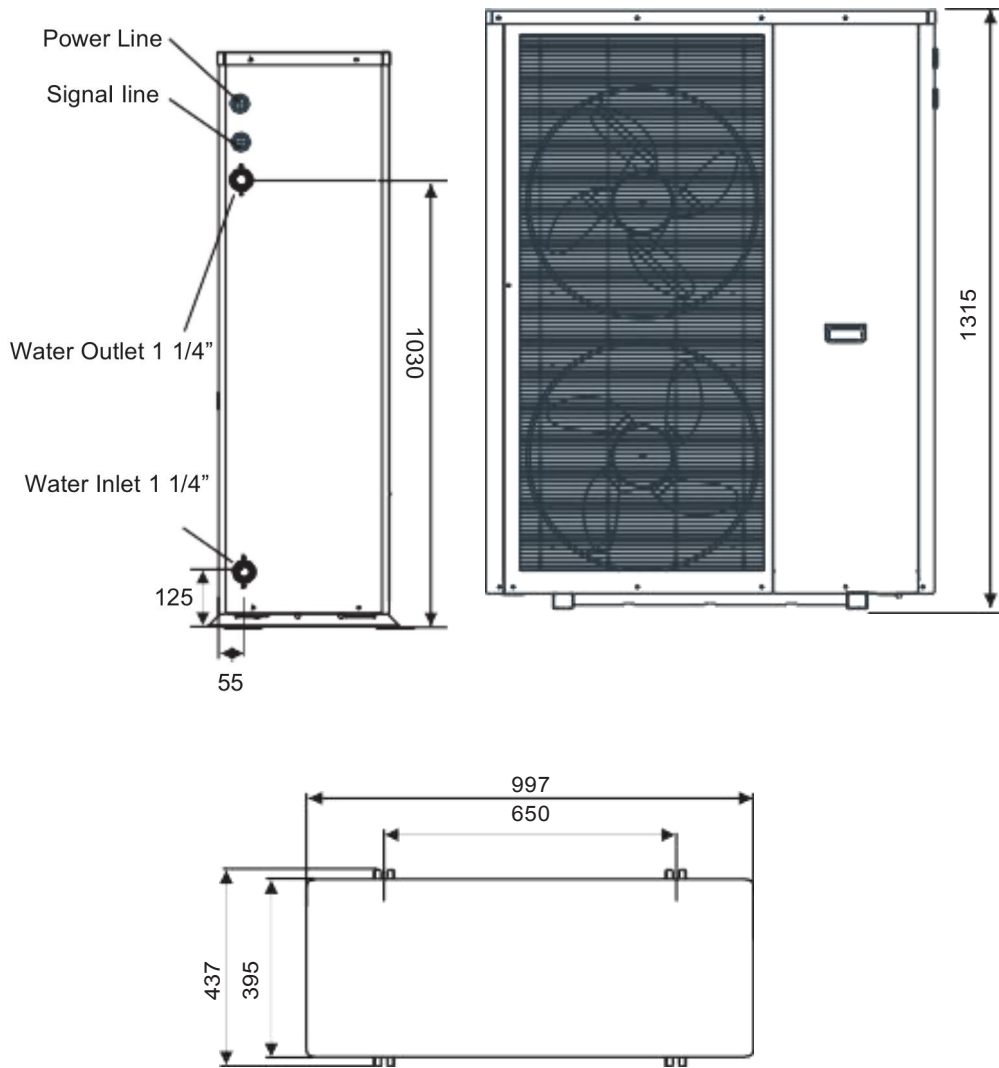

**4.4. Models: CH-HP24UIMPRM**

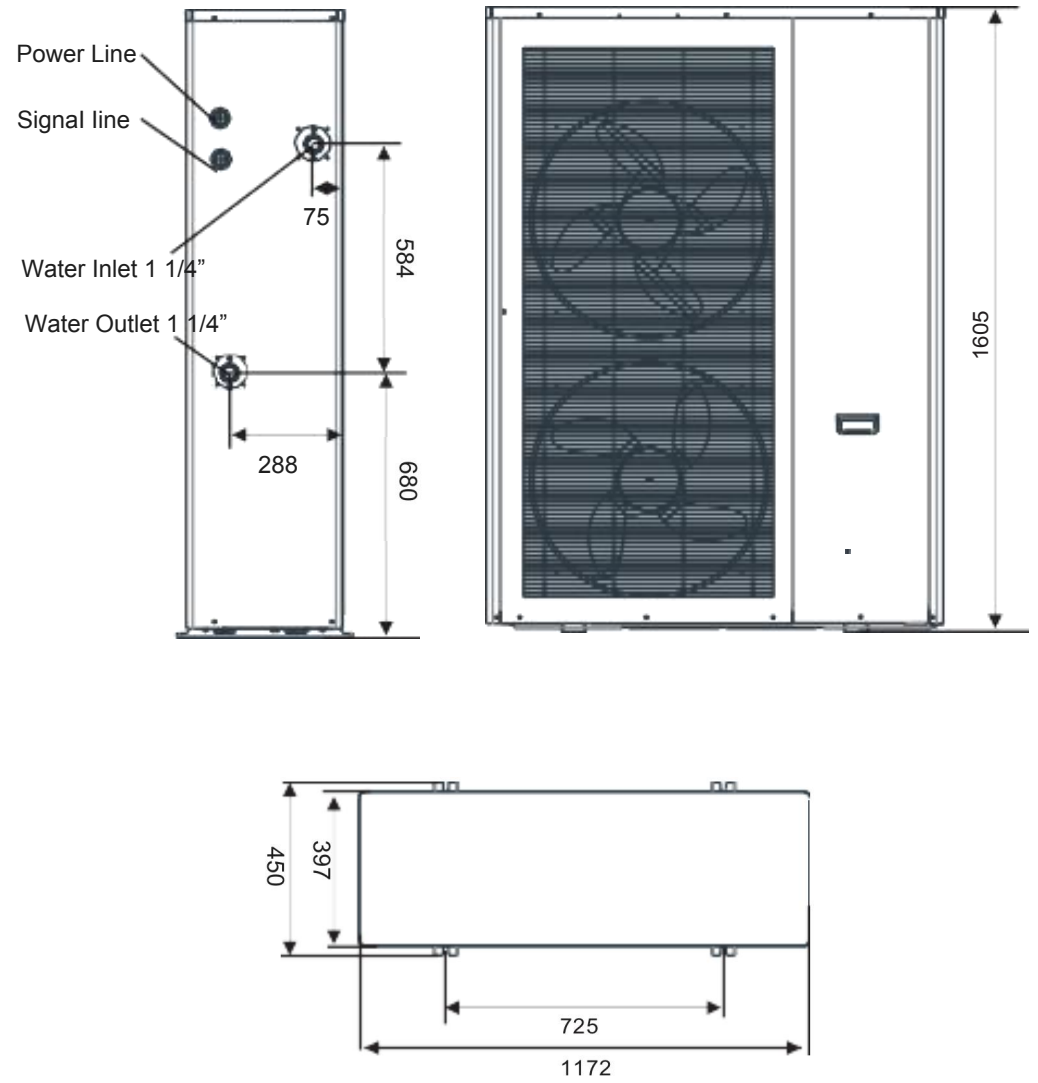

## 5. Installation Diagram

Monoblock heat pumps can provide heating/cooling and domestic hot water. Floor heating loops and fan coil units are used for space heating and fan coil units are used for space cooling. Domestic hot water is supplied from the domestic hot water tank connected to the heat pump.

### 5.1 Traditional Installation

Provides the monoblock heat pump with main circulation pump built inside. When install the unit, installer should connect the heat pump with other parts including the buffer tank (for space heating/cooling), storage water tank (for domestic hot water) and water pumps (for space heating/cooling water circulation and domestic hot water). External fittings are also needed including the safety valve, water charge valve, hot water valves (three-way valve). Temperature sensor should be added in the storage water tank. Additional electric heater can be installed in the DHW tank or the buffer tank which can get the control signal from the heat pump.

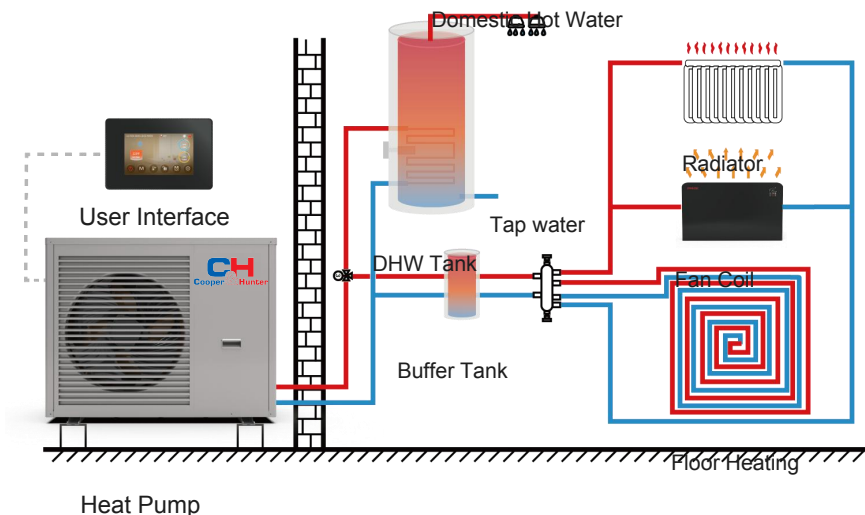

### 5.2 Installation with Hydronic Box

Provides the monoblock heat pump (without circulation pump) and the Hydronic box. Hydronic box includes one small size built-in buffer tank, one main circulation water pump, one space heating/cooling circulation water pump, one DHW pump, safety valve, water charge valve and expansion tank, electrical heater. When install the unit, installer should connect the heat pump directly to the Hydronic box while the buffer tank (for space heating/cooling) is considered whether to add or not. Storage water tank is needed for the domestic hot water application. Temperature sensor should be added in the storage water tank.

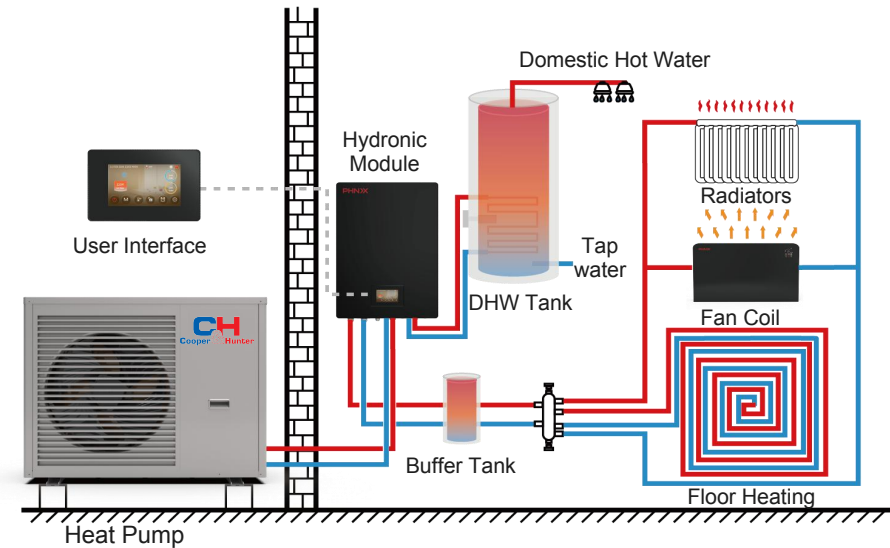

### 5.3 Installation with Multi-functions box



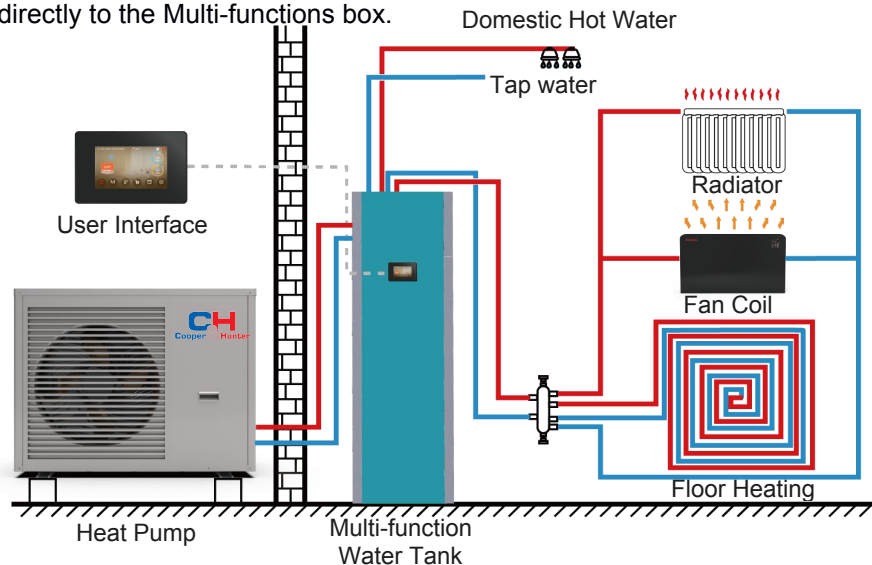



Provides the monoblock heat pump (without circulation pump) and the Multi-functions box. Multi-functions box includes one 50-liter buffer tank, one 150-liter storage tank, one main circulation water pump, one space heating/cooling circulation water pump, one domestic hot water pump, safety valve, water charge valve and hot water valve. When install the unit, installer just connect the heat pump directly to the Multi-functions box.





## 6. Handling & Installation

### 6.1. Packing List

	<p>Heat Pump Unit × 1</p>
	<p>Display Mounting Plate × 1</p>
	<p>Rubber Feet × 4</p>
	<p>Drain Connection × 1</p>
	<p>Display Connecting Wire × 1</p>
	<p>Thermistor × 1 *optional accessory</p>

### 6.2. Installation Site Requirement (Unit: mm)

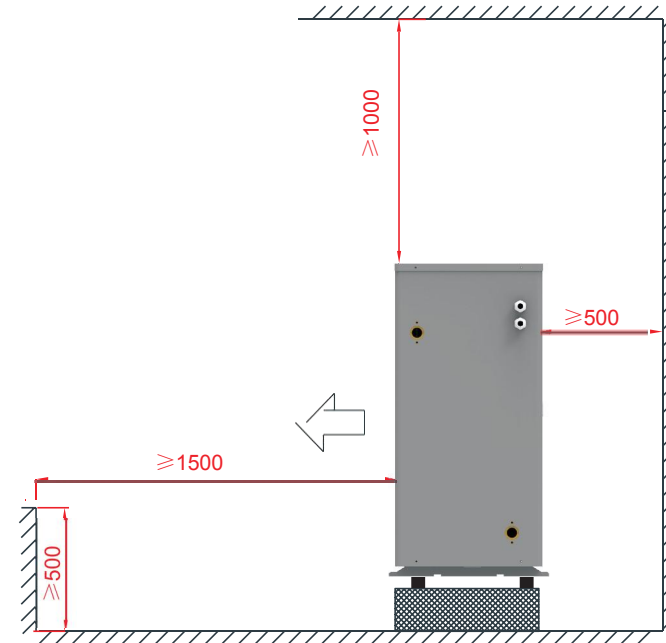
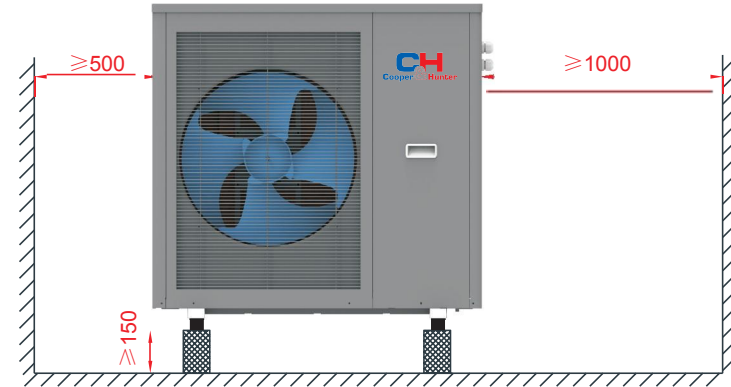

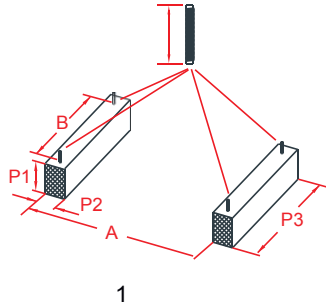
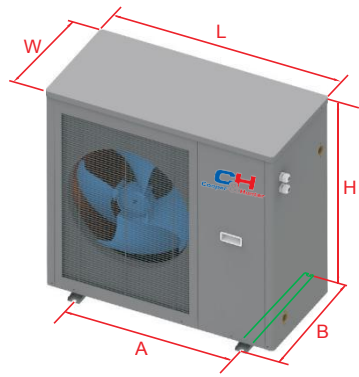

1

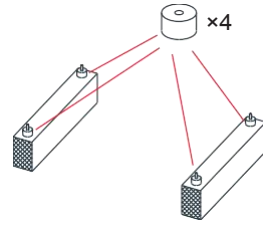

2



3

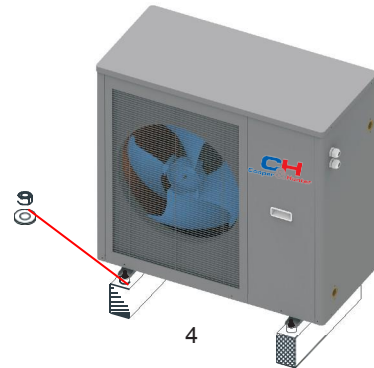

4

	P6	P10A/P10T	P17A/P17T	P24T
L	750	953	997	1172
H	805	915	1315	1605
W	442	423	395	397
A	750	700	650	725
B	473	443	400	415
A	1002	700	650	725
B				
P1	200	200	200	200

P2	150	150	150	150
P3	B+100	B+100	B+100	B+100

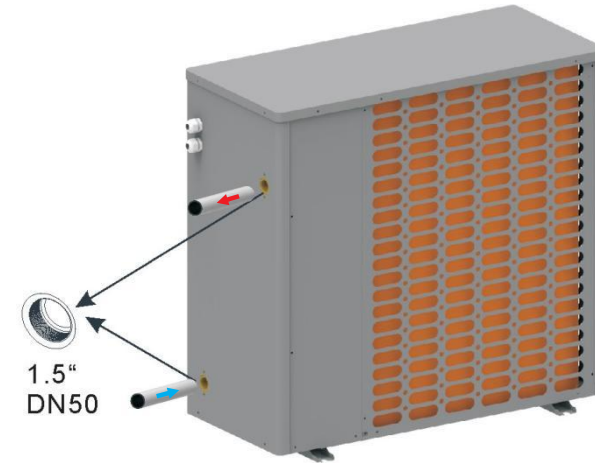

1.5"  
DN50

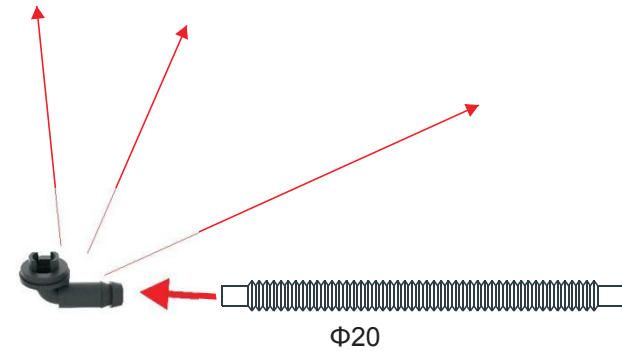

Φ20

Nameplate max. current	Phase line	Earth line	MCB	Creepage protector	Signal line
Less than 10A	2×1.5 mm <sup>2</sup>	1.5 mm <sup>2</sup>	20A	30mA less than 0.1 sec	n×0.5mm <sup>2</sup>
10~16A	2×2.5 mm <sup>2</sup>	2.5 mm <sup>2</sup>	32A	30mA less than 0.1 sec	
16~25A	2×4 mm <sup>2</sup>	4 mm <sup>2</sup>	40A	30mA less than 0.1 sec	
25~32A	2×6 mm <sup>2</sup>	6 mm <sup>2</sup>	40A	30mA less than 0.1 sec	
32~40A	2×10 mm <sup>2</sup>	10 mm <sup>2</sup>	63A	30mA less than 0.1 sec	
40 ~63A	2×16mm <sup>2</sup>	16mm <sup>2</sup>	80A	30mA less than 0.1 sec	
63~75A	2×25 mm <sup>2</sup>	25mm <sup>2</sup>	100A	30mA less than 0.1 sec	
75~101A	2×25 mm <sup>2</sup>	25mm <sup>2</sup>	125A	30mA less than 0.1 sec	
101~123A	2×35 mm <sup>2</sup>	35 mm <sup>2</sup>	160A	30mA less than 0.1 sec	
123~148A	2×50 mm <sup>2</sup>	50 mm <sup>2</sup>	225A	30mA less than 0.1 sec	
148~186A	2×70 mm <sup>2</sup>	70 mm <sup>2</sup>	250A	30mA less than 0.1 sec	
186~224A	2×95 mm <sup>2</sup>	95 mm <sup>2</sup>	280A	30mA less than 0.1 sec	

Nameplate maximum current	Phase line	Earth line	MCB	Creepage protector	Signal line
Less than 10A	3×1.5 mm <sup>2</sup>	1.5mm <sup>2</sup>	20A	30mA less than 0.1 sec	n×0.5mm <sup>2</sup>
10~16A	3×2.5 mm <sup>2</sup>	2.5mm <sup>2</sup>	32A	30mA less than 0.1 sec	
16~25A	3×4 mm <sup>2</sup>	4mm <sup>2</sup>	40A	30mA less than 0.1 sec	
25~32A	3×6 mm <sup>2</sup>	6mm <sup>2</sup>	40A	30mA less than 0.1 sec	
32~40A	3×10 mm <sup>2</sup>	10mm <sup>2</sup>	63A	30mA less than 0.1 sec	
40 ~63A	3×16mm <sup>2</sup>	16mm <sup>2</sup>	80A	30mA less than 0.1 sec	
63~75A	3×25mm <sup>2</sup>	25mm <sup>2</sup>	100A	30mA less than 0.1 sec	
75~101A	3×25 mm <sup>2</sup>	25mm <sup>2</sup>	125A	30mA less than 0.1 sec	
101~123A	3×35 mm <sup>2</sup>	35mm <sup>2</sup>	160A	30mA less than 0.1 sec	
123~148A	3×50 mm <sup>2</sup>	50mm <sup>2</sup>	225A	30mA less than 0.1 sec	
148~186A	3×70 mm <sup>2</sup>	70mm <sup>2</sup>	250A	30mA less than 0.1 sec	
186~224A	3×95 mm <sup>2</sup>	95mm <sup>2</sup>	280A	30mA less than 0.1 sec	

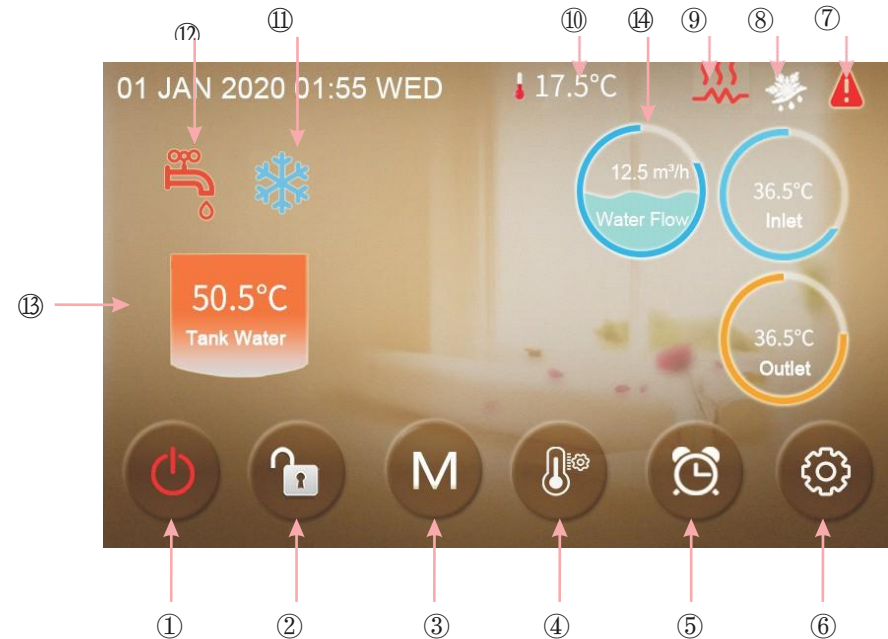

Key No.	Key Name	Key Function
①	ON/OFF	Switch the unit ON or OFF. Red represents ON, while gray represents OFF.
②	Lock Screen	Lock the screen. White represents disabled, while green represents enabled.
③	Running Mode	Switch to Hot water mode, heating mode, cooling mode, hot water + heating mode or hot water + cooling mode
④	Temperature Setting	Set the target temperature.
⑤	Timer Setting	Set the timer. White represents disabled, while green represents enabled.

⑥	Setup	Check the unit status, time, factory parameter, temperature curve, timer setting and mute setting.
⑦	Fault	This icon will flash when there is an error showing up. The display will enter fault record interface after tapping this icon.
⑧	Defrosting	The unit is in defrosting mode when this icon shows up.
⑨	Electric Heater	The unit is in electric heater mode when this icon shows up.
⑩	Ambient Temperature	It shows the current ambient temperature.
⑪	Cooling Mode	The unit is in cooling mode when this icon shows up.
⑫	Hot Water Mode	The unit is in hot water mode when this icon shows up.
⑬	Tank Water Temperature	The unit is in hot water mode when this icon shows up; Otherwise, this icon is not shown.
⑭	Water Flow	It shows the current water flow (note: When H31=0, the icon is not displayed).

Before starting up the unit for the first time or after a long-time shutdown, the following preparations must be made:

- (1) Thoroughly inspect and clean up the unit.
- (2) Clean the waterway system.
- (3) Check water pump, regulating valve and other waterway equipment.
- (4) Tighten all wire connections.

Do not change the system parameters before consulting the engineer.

Ensure the water refill and exhaust device in the waterway is well, otherwise the performance and reliability of the unit will become worse.

Ensure the waterways are clean and avoid dirt and blockage.

Timely check the electrical, water and replace the faulty parts.

Please use the parts provided or recommended by the company, do not use the parts unqualified.

Refrigerant supplement:

Each unit has been equipped with sufficient refrigerant when leaving the factory. Do not charge or change the refrigerant.

If you need to replenish the refrigerant due to leakage, please contact the engineer or dealer.

## 7.2. Periodic Maintenance (every 6 months)

Preparation	Before maintenance, please ensure that the unit stop running and cut off the power supply.
Inspection and cleaning of fin heat exchanger	In order to ensure that heat exchangers remain in optimum condition for heat exchange, their surfaces must be kept clean.
Inspection and cleaning of plate heat exchanger	Every 6 months or when the capacity of the unit drops by more than 10%, check the water-side heat exchanger for scale and clean the heat exchanger.
Check the electrical wiring	Check if the contact point is loose, oxidized, or blocked by sundries, etc., which causes poor contact of the electronic wiring.

## 7.3. Inspection and Maintenance

### 7.3.1. Preparing for inspection and maintenance

#### **Danger!**

#### **Risk of death caused by fire or explosion if there is a refrigerant leakage!**

Only carry out the work if you are competent and have knowledge about the special features and risks of R32 refrigerant.

The product contains combustible refrigerant R32. In the event of a leak, escaping refrigerant may mix with air to form a flammable atmosphere. There is a risk of fire and explosion.

Ensure that space is sufficiently aerated around the product.

Observe the basic safety rules before carrying out inspection and maintenance work or installing spare parts.

Disconnect the product from the power supply but ensure that the product is still earthed.

### 7.3.2. Cleaning the product

Do not clean the product with a high-pressure cleaner or a direct jet of water.

Clean the product using a sponge and hot water with a cleaning agent.

Do not use abrasive cleaners. Do not use solvents. Do not use any cleaning agents that contain chlorine or ammonia.

### 7.3.3. Checking the evaporator, fan, and condensate discharge

Check whether there is dirt between the fins or whether depositions have adhered to the fins.

Clean the fins using a soft brush, avoid fins from being bent.

Check whether dirt has accumulated on the condensate tray or in the condensate discharge pipe.

Check that the water can drain freely.

## 7. Parameters

Model		CH-HP08UIMPRK	CH-HP12UIMPRM	CH-HP20UIMPRM	CH-HP24UIMPRM
Power Supply	/	230V~/30~90Hz	380V/3N~/30~90Hz	380V/3N~/30~90Hz	380V3N~/30~90Hz
Moisture Resistance	IPX	IPX4	IPX4	IPX4	IPX4
Electrical Shockproof	I	I	I	I	I
Heating Condition - Ambient Temp. (DB/WB): 7/6°C, Water Temp. (In/Out): 30/35°C					
Heating Capacity Range	kW	2.29~8.25	4.70~12.50	7.00~20.50	10.00~25.00
Heating Power Input Range	kW	0.63~1.81	1.08~3.44	1.50~6.00	2.80~5.70
Heating Current Input Range	A	3.2~8.0	2.1~5.7	2.5~10.0	4.67~10.17
Cooling Condition - Ambient Temp. (DB/WB): 35/24°C, Water Temp. (In/Out): 12/7°C					
Cooling Capacity Range	kW	1.98~6.10	3.22~11.30	5.50~15.50	6.4~15.80
Cooling Power Input Range	kW	0.70~2.22	1.27~4.64	1.50~6.00	3.4~6.80
Heating Current Input Range	A	3.3~9.7	2.4~7.6	2.5~10.0	6.28~11.6
Hot Water Function is available for all the sizes.					
Max. Power Input	kW	2.9	4.64	7.20	12.50
Max. Current Input	A	13.0	21.5	12.0	20.3
Water Flow	m <sup>3</sup> /h	1	1.7	2.9	4.2
Refrigerant / Proper Input	kg	R32 / 1.3kg	R32 / 1.7kg	R32 / 2.0kg	R32 / 3.4kg
Equivalent	Ton	0.88	1.08	1.35	2.27
Sound Pressure (1m)	dB(A)	37~54	42~55	44~58	53~59
Unit Dimension(L/W/H)	mm	1002×490×805	953×460×915	953×437×1315	1178×450×1605
Shipping Dimension(L/W/H)	mm	1070×510×970	1050×500×1060	1050×450×1470	1220×500×1780
Compressor	Brand	Panasonic	Panasonic	Panasonic	Panasonic
Circulation Pump	Brand	GRUNDFOS	GRUNDFOS	GRUNDFOS	GRUNDFOS
Operating Ambient Temperature	°C	-25~43	-25~43	-25~43	-25~43
Fan Quantity	/	1	1	1	2
Fan Motor Type	/	DC motor	DC motor	DC motor	DC motor
Fan Motor Power Input (Min~Max)	W	30~75	30~93	30~73	60~150
Fan Speed (RPM)	RPM	300~850	300~800	300~800	300~800
Connection (Inch)	Inch	1	1	1	1 1/4
Water Pressure Drop (max)	kPa	28	35	35	68
Circulation Pump Water Head	m	5.5	5.5	12.5	21

### 9. Wiring Diagram

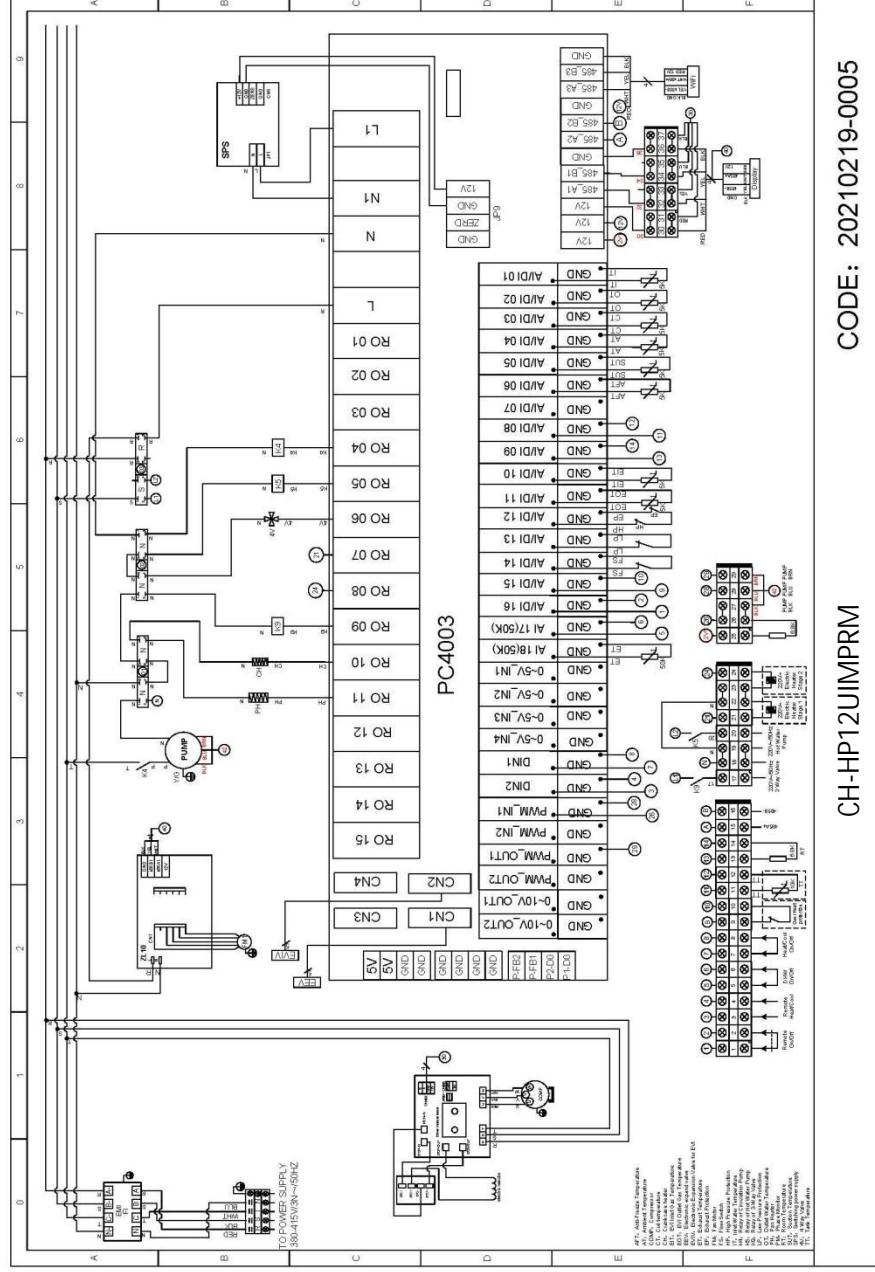
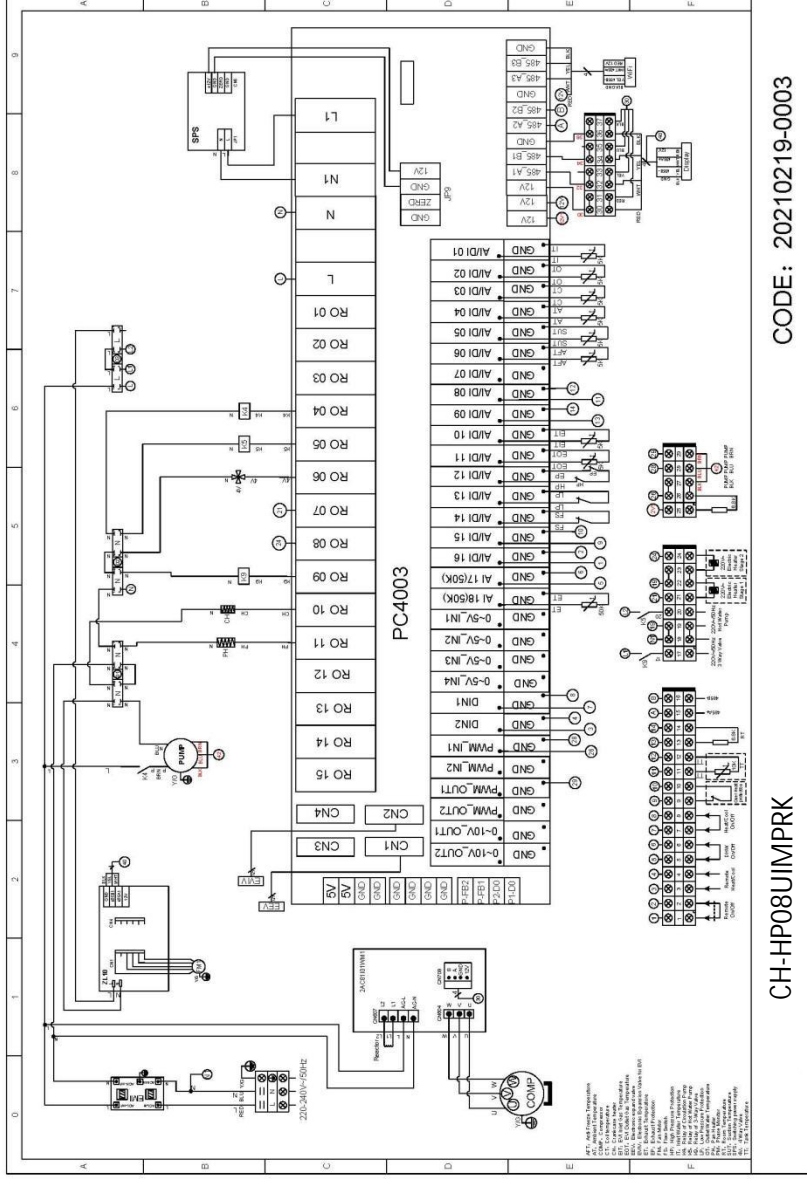

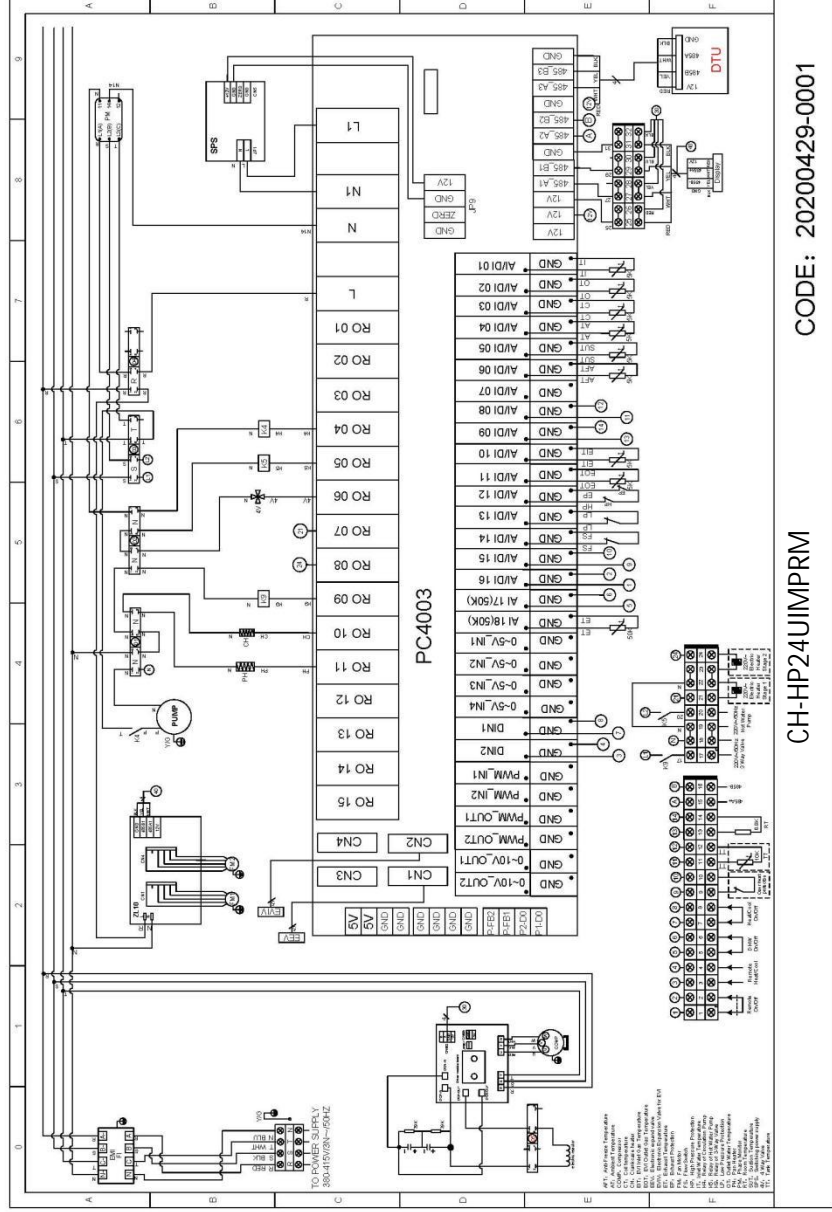
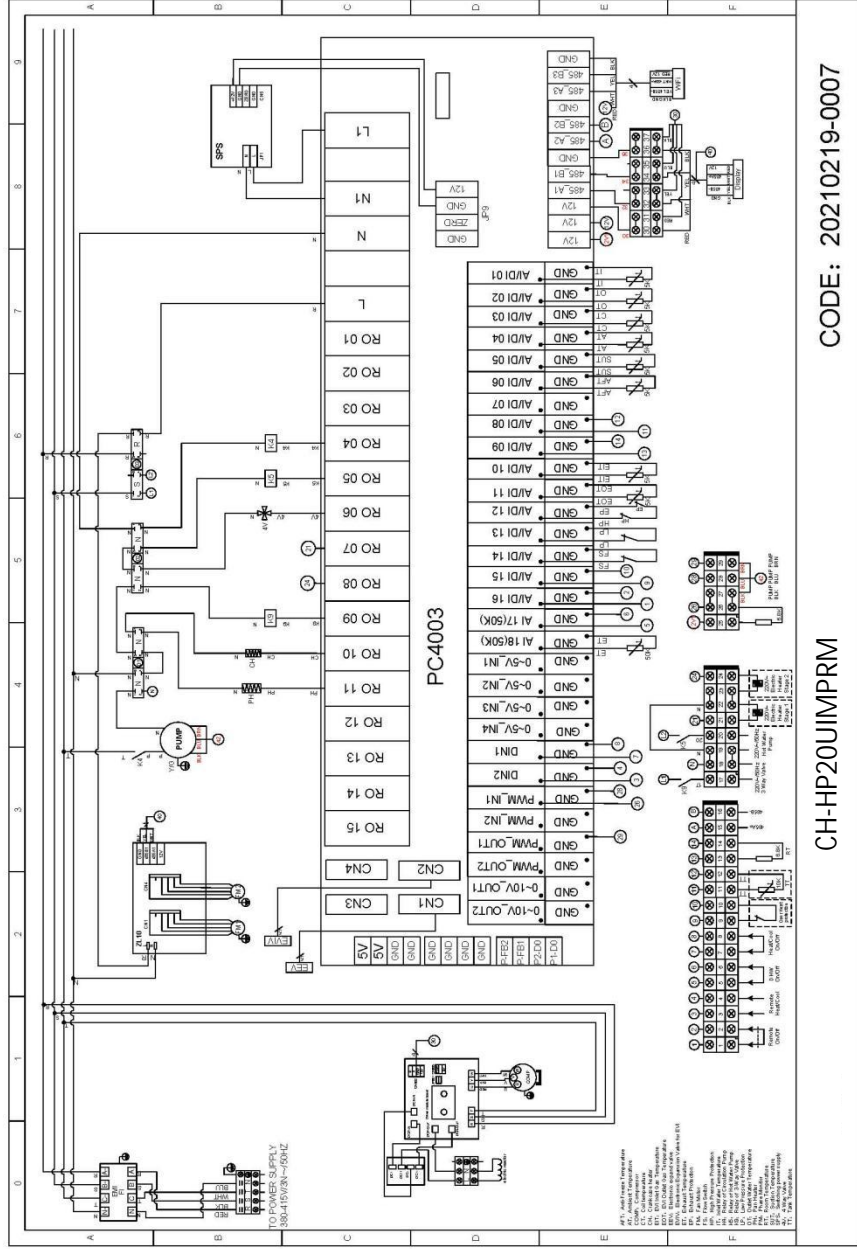



## 10. Display Operation Guide

### 10.1. Main Interface Display and Function

#### (1) Power on Interface

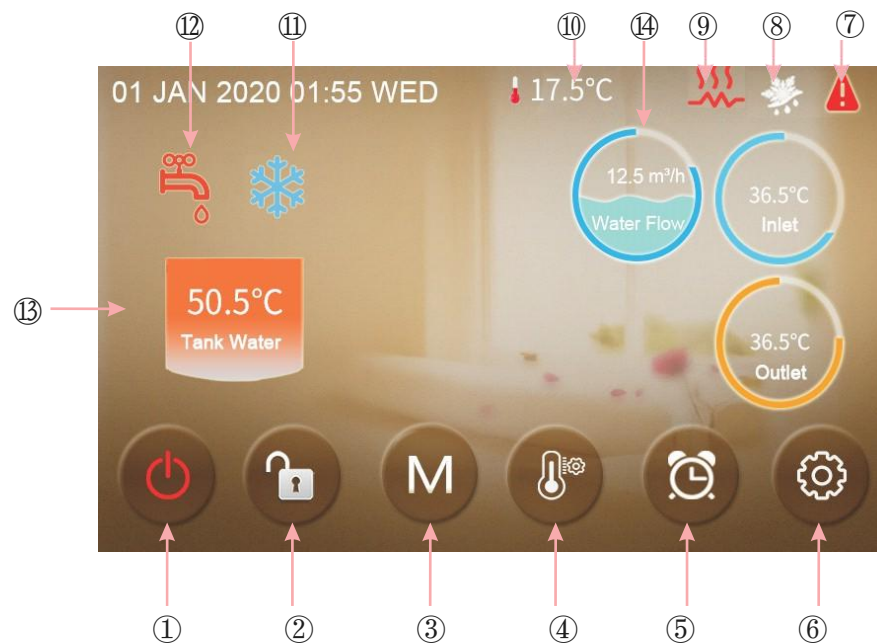

Key No.	Key Name	Key Function
①	ON/OFF	Switch the unit ON or OFF. Red represents ON, while grey represents OFF.
②	Lock Screen	Lock the screen. White represents disabled, while green represents enabled.
③	Running Mode	Switch Hot water mode, heating mode, cooling mode, hot water + heating mode or hot water + cooling mode
④	Temperature Setting	Set the target temperature.
⑤	Timer Setting	Set the timer. White represents disabled, while green represents enabled.
⑥	Setup	Check the unit status, time, factory parameter, temperature curve, timer setting and mute setting.
⑦	Fault	This icon will flash when there is an error showing up. The display will enter fault record interface after tapping this icon.
⑧	Defrosting	The unit is in defrosting mode when this icon shows up.
⑨	Electric Heater	The unit is in electric heater mode when this icon shows up.
⑩	Ambient Temperature	It shows the current ambient temperature.
⑪	Cooling Mode	The unit is in cooling mode when this icon shows up.
⑫	Hot Water Mode	The unit is in hot water mode when this icon shows up.
⑬	Tank Water Temperature	The unit is in hot water mode when this icon shows up; Otherwise, this icon is not shown.
⑭	Water Flow (Only available for some models. Will be available for all before Dec. 2021)	It shows the current water flow (note: When H31=0, the icon is not displayed).

## 10.2. ON/OFF

As the main interface shows

(1) In the shutting down interface (on/off key is in grey status), press the on/off key can start up the machine.

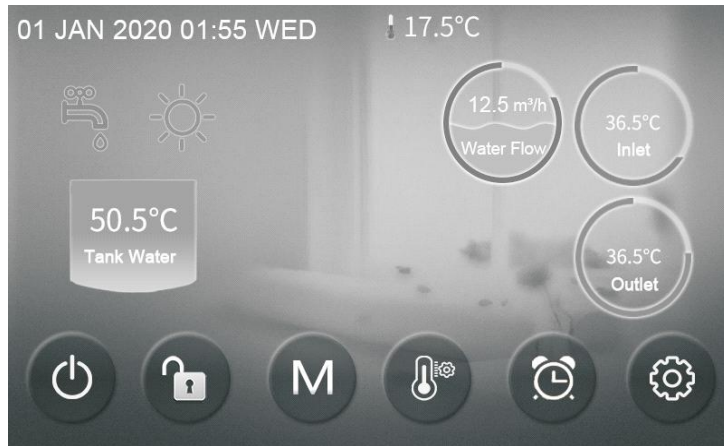

(2) Note: In starting up interface (on/off key is in red status), press the on/off key can shut down the machine.

## 10.3. Mode Switch

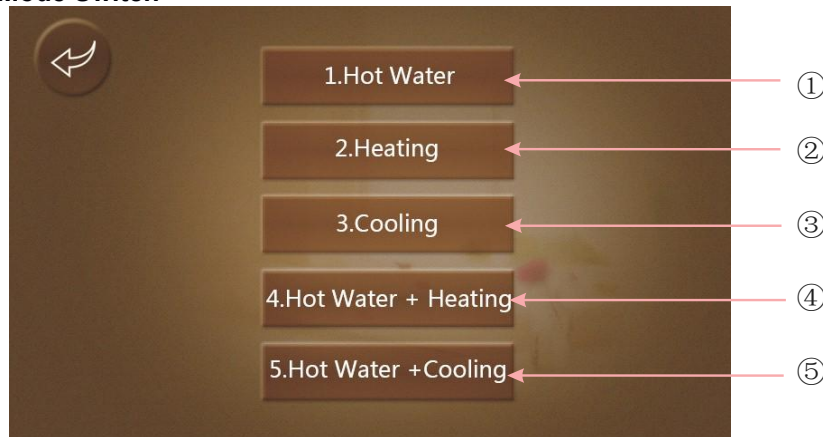

In the main interface, there are five modes that can be selected after tapping the mode key.

(1) tapping hot water mode icon ①, then the display will change to this mode's interface;

(2) tapping heating mode icon ②, then the display will enter this mode's interface;

(3) tapping cooling mode icon ③, then the display will switch to this mode's interface;

(4) tapping hot water + heating mode icon ④, then the display will go into the hot

water + heating mode's interface;

(5) tapping hot water + cooling mode icon ⑤, then the display will come to the hot water + cooling mode's interface;

Note: If your unit is a heating-only model (without a cooling function), the "cooling" key will show on the interface.

## 10.4. The setting of Target Temperature

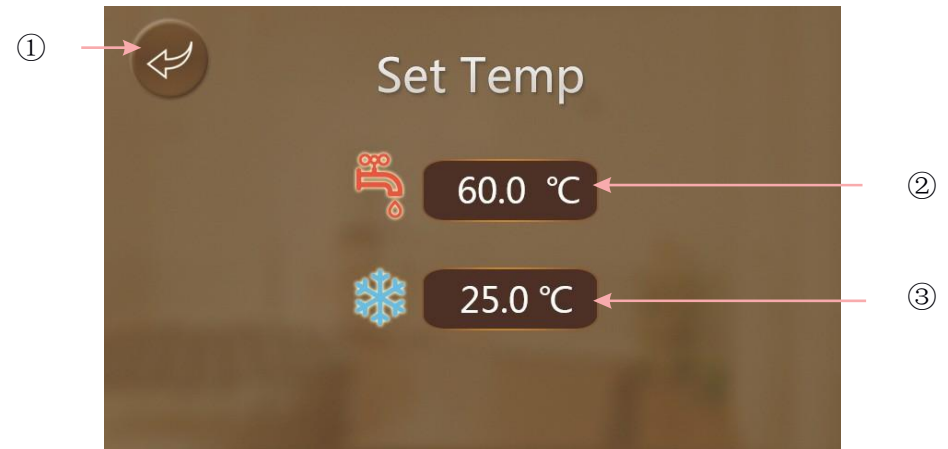

Take hot water + cooling mode for example:

Tapping ①, the wire controller will back to the main interface;

Tapping ②, the target temp of hot water can be set by the pop-up keyboard;

Tapping ③, the target temp of cooling mode can be set by the pop-up keyboard.

## 10.5. When the target temp is being set, the pop-up keyboard is shown as following:

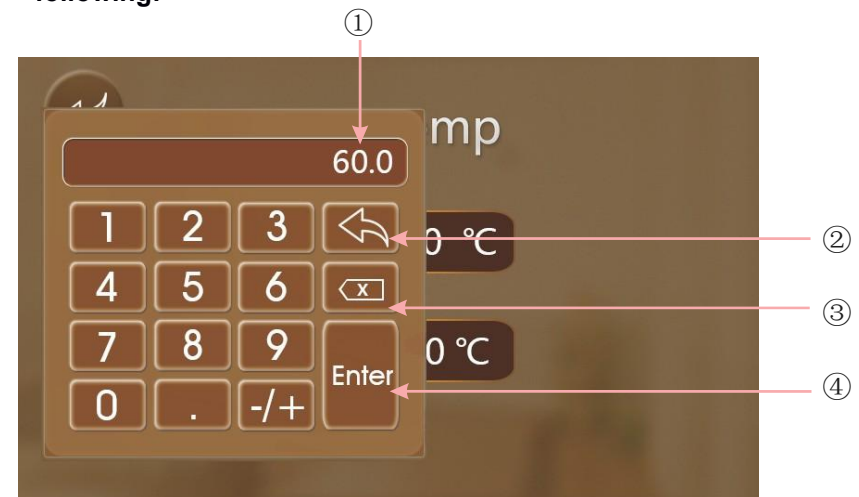

Key No.	Key Name	Key Function
②	Return key	Tapping this key can back to the main interface.
③	Delete key	Tapping this key to undo the last action.
④	Enter key	Tapping this key can save you action and back to the main interface.

Note: ① means the new target temp under the current setting

### 10.6. Unlock Screen

Click the lock screen key again while the screen has been locked, the pop-up keyboard is shown as following:

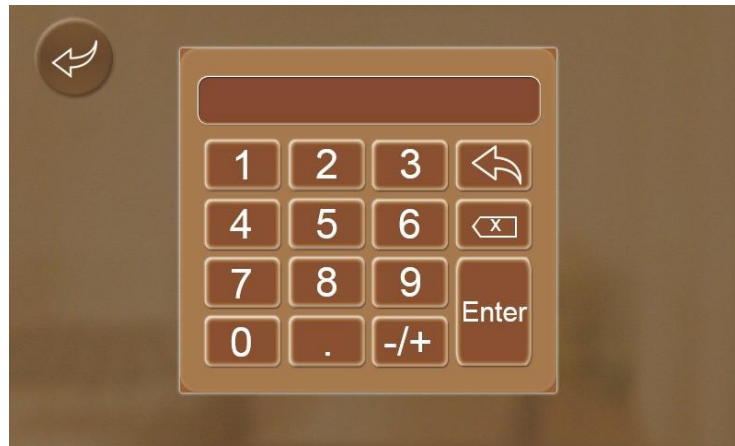

Note: Input the password of 22 or 022 and click the enter key, the screen will be unlocked.

### 10.7. Timer Setting

Click the timer setting key to enter the timer setting, the interface display is as follows:



Key No.	Key name	Key color	Key function
①	Return key		Click this key to return to the main interface.
②	Enable the timer on/off	Enable: Green ON Disable: Gray OFF	Click this key to start or turn off the timed function
③	Enable the timer off	Enable: Red ON Disable: Gray OFF	Click this key to start or turn off the timed shutdown function
④	Hour of timer on		Click this button to set the timing boot time
⑤	Hour of timer off		Click this button to set the scheduled shutdown time
⑥	Page left		Click this button to turn the page left
⑦	Page right		Click this button to turn page right

## 10.8. Setup

Click the setup key to enter the setup and the interface display is shown as follows:

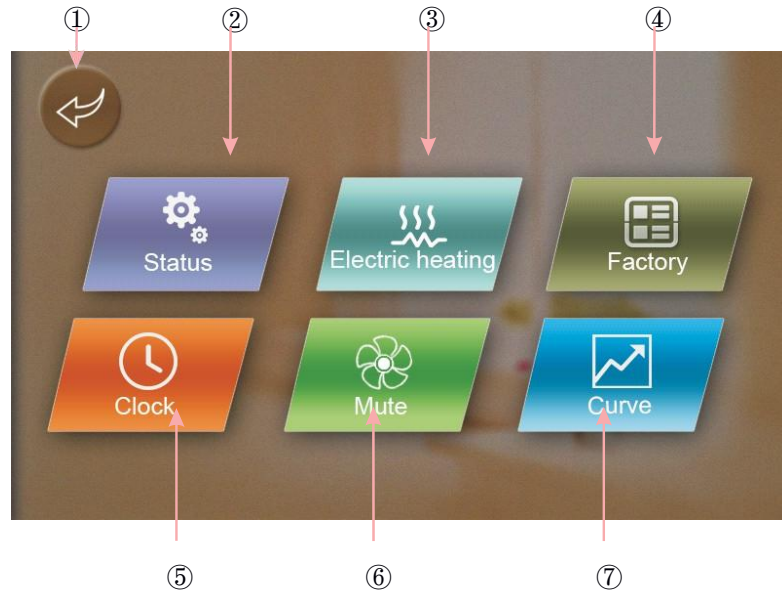

Key No.	Key Name	Key Function
①	Return key	Click this key to return to the main interface.
②	Operating mode	Click this key to view the current operating parameters of the unit.
③	Electric heating	Click this key to turn on the unit Electric heating.
④	Factory parameter	Click the key and enter the password to enter the factory parameter settings and status parameters interface.
⑤	System time setting	Click this key to set the system time.
⑥	Mute setting	Click this key to set the unit mute function mode.
⑦	Curve key	Click this key to view the temperature curve.

Note:

If the unit has ②, ⑥ or both functions, the corresponding icon will be displayed on the setting interface.

In the setup interface:

(1) Tapping operating mode button ②, then the interface display is shown as follows:

(2) Tapping system time setting button ⑤, then the interface display is shown as follows:



Key No.	Key Name	Key Function
①	Return key	Click this key to return to the setup interface.
②	Up key	Click this key to increase the value.
③	Down key	Click this key to decrease the value.
④	Cancel key	Click this key to cancel the current settings and return to the settings page.
⑤	Enter key	Click this key to save the current settings.

(3) Tapping Electric heating button ③, then the interface display is shown as follows:

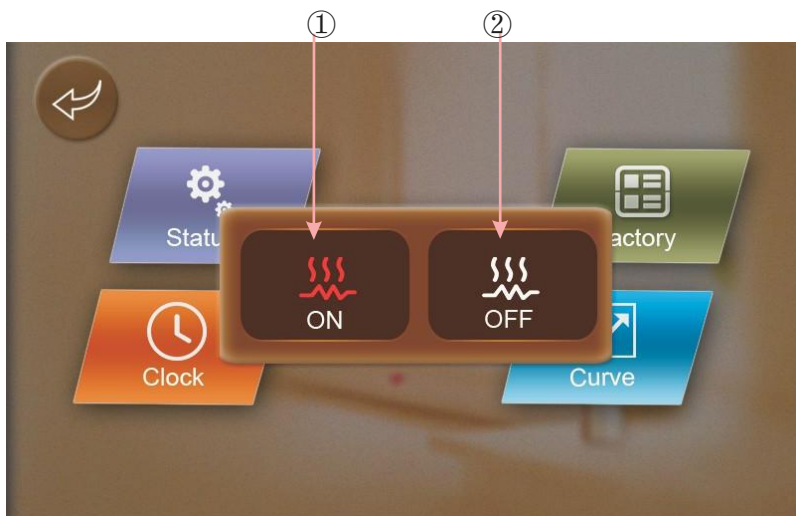

**Note:**

When the unit starts the electric heating, the icon is displayed as ①; When the unit closes the electric heating, the icon is displayed as ②;

While the unit is in cooling mode, clicking the icon ①, the electric heating will not be turned on;

While the unit is in hot water + cooling mode, if the hot water side is running, the electric heating will be operated and shown; if the cooling side is running, clicking the icon ①, the electric heating will not be turned on.

(4) Tapping Mute setting button ⑥, then the interface display is shown as follows:

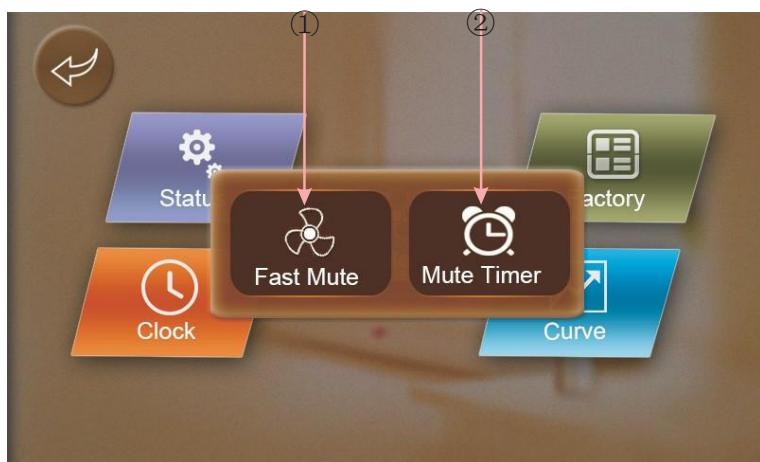

Note: When the unit is enabled to activate the mute function, the icon ① is

displayed as ; When the unit is enabled to activate the powerful function, the icon ① is displayed as .

(4.1) Tapping Mute Timer button ②, then the interface display is shown as follows:

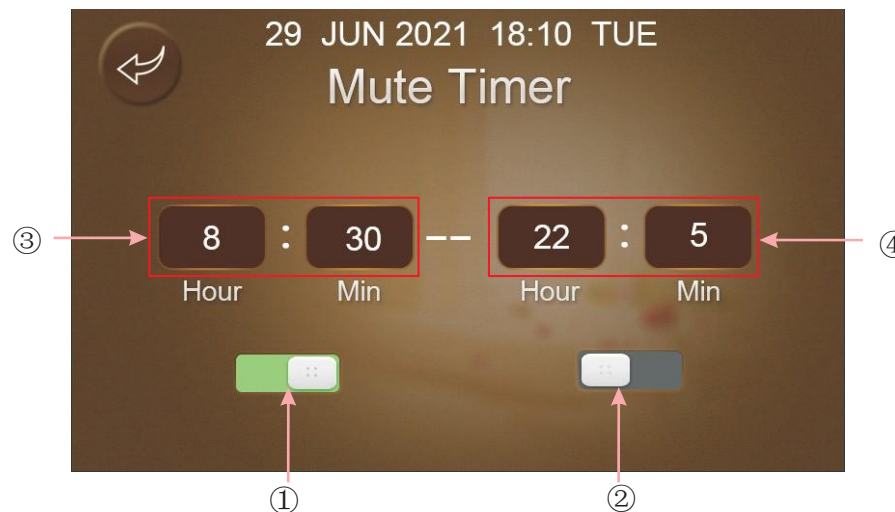

Key No.	Key Name	Key color	Key Function
①	Timing Mute Start Enabled	Enable: Green ON Disable: Gray OFF	Click this key to start or turn off the timed mute start enable
②	Timed mute end enabled	Enable: Red ON Disable: Gray OFF	Click this key to start or turn off the timed mute end enable
③	Timing mute start time		Click this button to set the timing mute start time
④	Timed mute end time		Click this button to set the timed mute end time

(5) Tapping Curve button⑦, then the interface display is shown as follows:

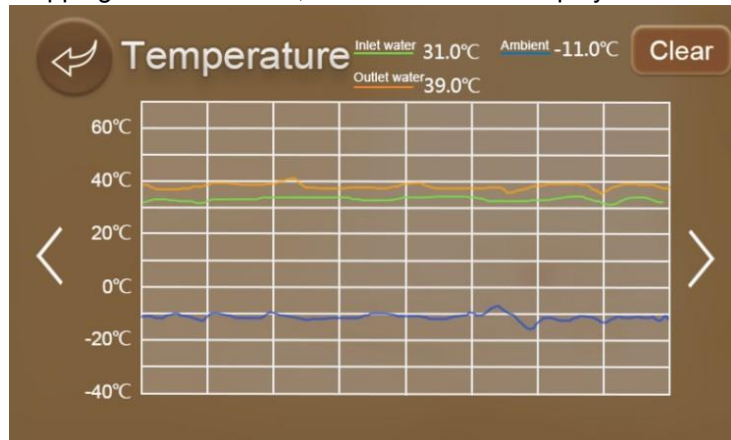

- This curve function records the water inlet temperature and water outlet temperature;
- Temperature data is collected every five minutes and the 12 sets of temperature data are saved every hour. Timekeeping is made from the latest data saving, if the power is disrupted when the time is less than 1 hour (12 sets), the data during such period will not be saved.
- Only curve for power-on status is recorded, and that for power-off will not be saved;
- The value of the abscissa indicates the time from the point on the curve to the current time point. The leftmost point on the first page (0 on the abscissa) is the latest temperature record;
- Temperature curve record is provided with power-down memory function.

## 10.9. Parameter backup and reset function

Input '855' to have the backup and reset function.

### 10.9.1. Backup and Reset Display

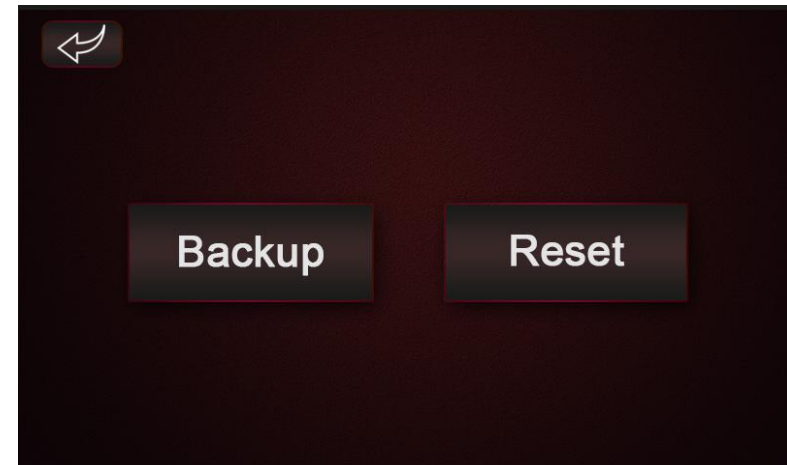

### 10.9.2. Parameter Backup

- The backup function means that backup the mainboard parameter setting to the display for stock. This function only suggests for use during the unit production, which can back up the unit factory setting on the display for storage;
- Push the "Backup" button, it can choose the yes or no to confirm the parameter backup;

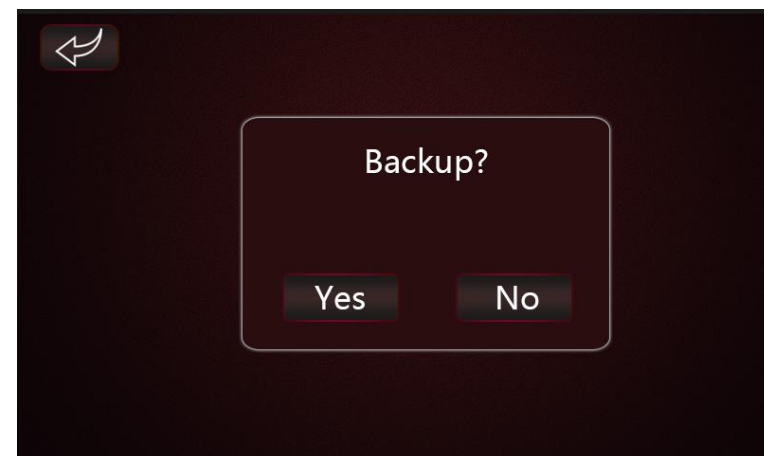

(3) After the data have been successfully backup to the display, it will show as below, otherwise, it will show the “failed” reminder;

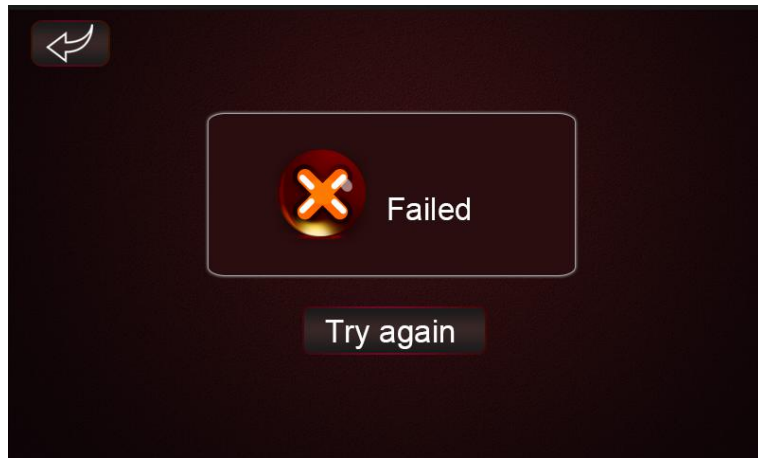
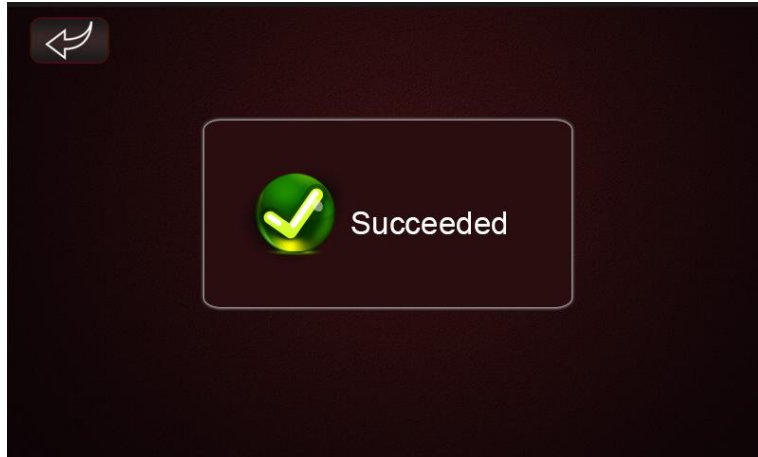

### 10.9.3. Parameter Reset

(1) The parameter reset means the reset the parameter according to the display backup parameter setting, if the unit only have done the backup function during the production, then the unit parameter reset can be reset the parameter to the factory setting;

(2) After pushing the “Reset” button, it will have below interface to choose the “Yes” or “No” to confirm whether to enable the reset function, during the parameter reset process, it will have the remind as “In recovery”, please do not have any operation during that time.



(3) After the data have been successfully reset from the display, it will show as below, otherwise, it will show the “failed” reminder;

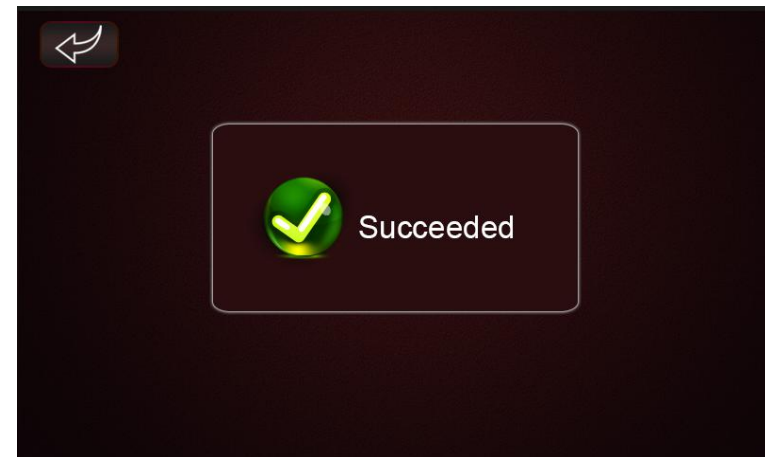

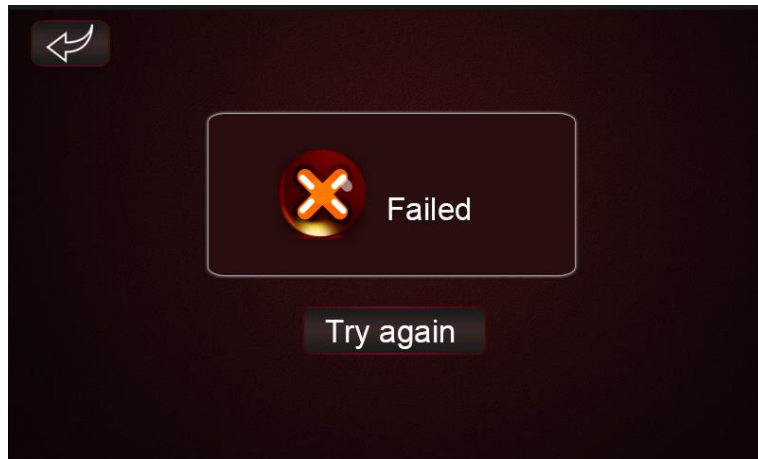

Please pay attention to the parameter backup and reset operation, as different model units have different parameter setting, if the unit has replaced a new display that did not belong to this model, please backup the parameter settings to the display at first;

#### 10.9.4. Failure Interface

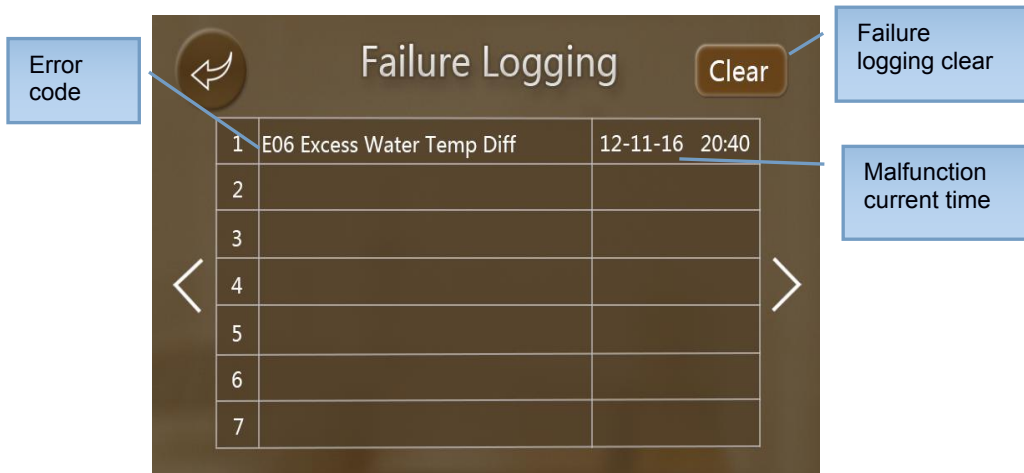

(1) When the unit get the alarm, it will have the alarm icon  on the main interface top right corner, click the icon then it will enter into the failure record interface.

#### (2) Failure record interface

- (a) The failure record interface will have the failure code and failure name as well as the failure time;
- (b) If it needs to clear the failure record, it needs to enter the password according to the display data, such as the display date is 19.06.2021, then the password should be "19";

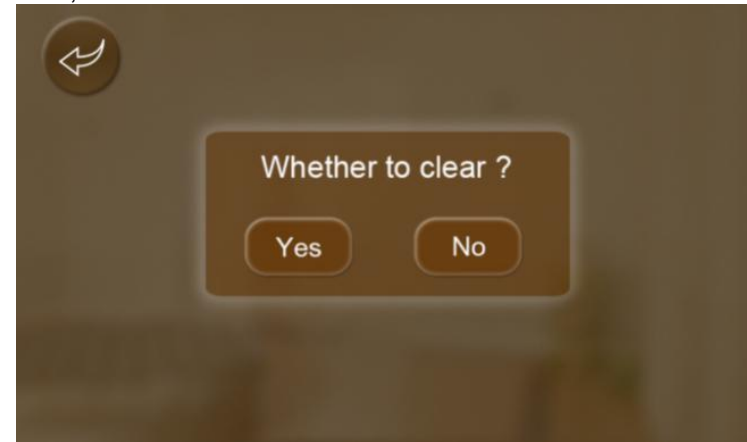

(c) When choosing the "Yes" to clear the failure record, if the failure did not be resolved, the failure record will keep on the record interface also;

#### 10.9.5. Locking Window Function

(1) When the main window has been locked, it will show as below:

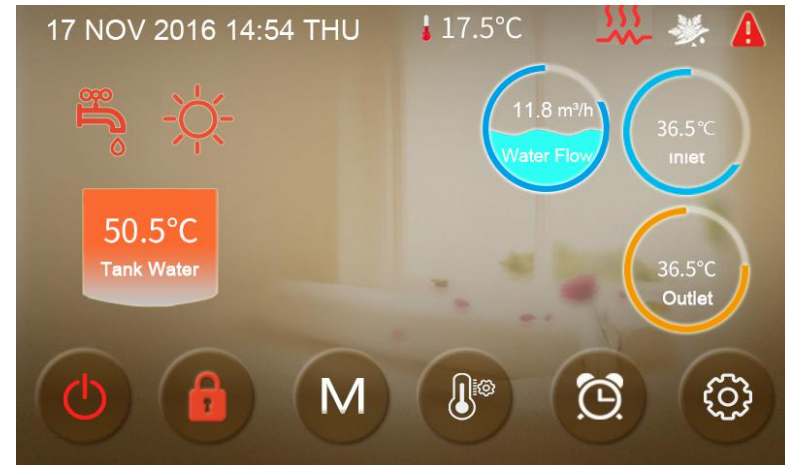

(2) Unlock the mainboard window

Click the "lock" key to unlock the window, it needs to input the password 22 or 022;



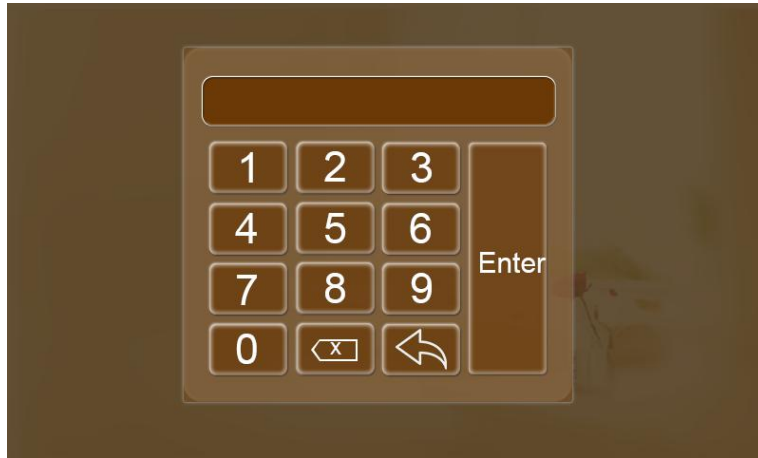

### 10.9.6. Weather Compensation Function

It needs to set the “slope” and “offset” value according to the customer house heating demand;

$$\text{Compensated target temp} = - \text{Slope} \times \text{Current ambient temp} + \text{Offset};$$

When the house heating needs more energy only during the low ambient temp, then it should enlarge the “Slope” setting;

When the house heating needs more energy during the whole ambient temp range, then it should enlarge the “Slope” and “Offset” setting;

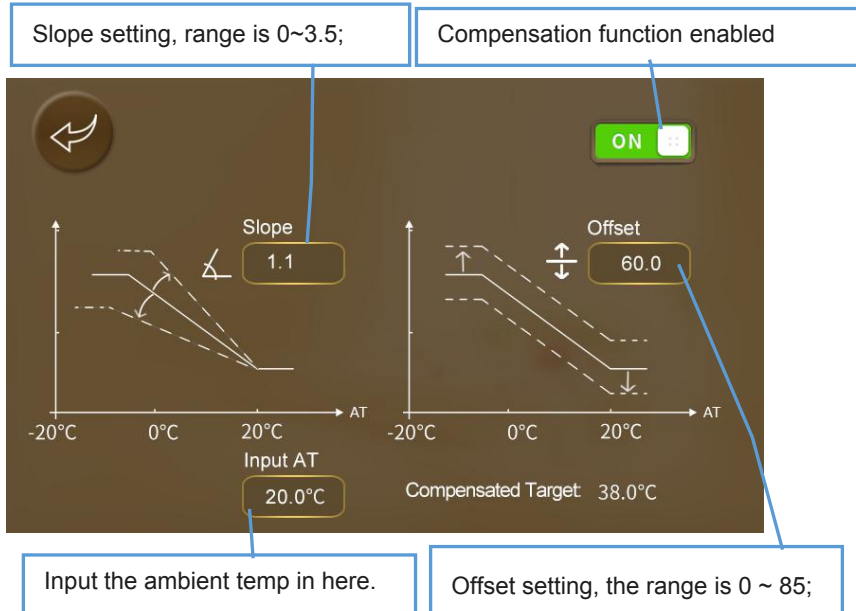

	<b>Possible cause</b>	<b>Related components</b>	<b>Solution</b>
Unit tripped when powered on	Short circuit	Terminals Relays Contactors cables	Check all the components' connection Check relays and contactors whether are broken Disconnect the electronic components one by one and powered on to find the problem
Display cannot get power	Cables has disconnected The power input cable is misconnected	Display cable Power input cable	Check the display cable Check the power cable Check the 3-phase power cable whether connected in right phase sequence
cannot start up the unit	The unit have error Cables has disconnected	Display Cables	Check the display whether shown error Check the cable Reconnect the power cable and check if it works
Display cannot work	The display has been locked The display is broken	Display	Check the display whether shown locked icon Check the cable Reconnect the power cable and check if it works
Heating effect is not good	The compressor running low frequency The fan is not running or speed is too low Leakage problem	Compressor Fan Refrigerant system	Check the compressor frequency Check the fan speed Check the exhaust temperature and low pressure
Shut off while didn't reach the target temperature	Temperature limit (according to ambient temperature)	Control logic	Check the parameters
The evaporator has too much frost and cannot defrosting cleanly	Fan blade or motor issue EEV step is not suitable Refrigerant amount issue Parameters issue	Parameters Fan EEV Refrigerant system	Check the defrosting parameters Check the compressor frequency Check the fan speed Check the exhaust temperature and low pressure
Abnormal noise	Screws issue Fan blade or motor issue Compressor issue Components have collision	Screws Fan Compressor Other components (tubes, cables)	Check the screws Check the fan blade and motor Check the compressor Check other components

	<b>Error name</b>	<b>Relevant parts information</b>	<b>Review and resolve</b>
E04	Electric heater overheat Protection		<ol style="list-style-type: none"> <li>1. Check the Electrical heating Overheat protector open or not.</li> <li>2. Check the Electrical heater.</li> </ol>
E08	Communication failure between PCB and display	Communication error between PCB and DISPLAY	<ol style="list-style-type: none"> <li>1. Check cable connection of PCB and DISPLAY.</li> <li>2. Check the software version of PCB and DISPLAY.</li> </ol>
E11	HP Protection	HP switch is open	<ol style="list-style-type: none"> <li>1. Check whether showing the error after unit shutdown.</li> <li>2. Measure the discharge pressure when unit is running.</li> <li>3. Detect EEV step, suction pressure, inlet/outlet water discharge and suction temp.</li> <li>4. Release all the gas of the system and refill refrigerant according to the nameplate.</li> </ol>
E12	LP Protection	LP switch is open	<ol style="list-style-type: none"> <li>1. Check whether showing the error after unit shutdown.</li> <li>2. Measure the suction pressure when unit is running.</li> <li>3. Detect EEV step, discharge pressure, inlet/outlet water discharge and suction temp.</li> <li>4. Release all the gas of the system and refill refrigerant according to the nameplate.</li> </ol>
E19	Primary Anti-freezing Protection	Ambient temp. $\leq 0^{\circ}\text{C}$ , A04- $2^{\circ}\text{C}$ $\leq$ water inlet $\leq$ A04 $^{\circ}\text{C}$	It is the protection in winter. Once the water temperature rises up to A04+ $4^{\circ}\text{C}$ or the ambient temp is higher than 1, the error code disappears.
E29	Secondary Anti-freezing Protection	Ambient temp. $\leq 0^{\circ}\text{C}$ , water inlet $\leq$ A04- $2^{\circ}\text{C}$	It is the protection in winter. Once the water temperature up to A04+ $11^{\circ}\text{C}$ or the ambient temp is higher than 1, the error code disappears.
E19	Primary Anti-freezing Protection	Ambient temp. $\leq 0^{\circ}\text{C}$ , $2^{\circ}\text{C} \leq$ water inlet $\leq 4^{\circ}\text{C}$	It is the protection in winter. Once the water temperature rises up to $8^{\circ}\text{C}$ or the ambient temp is higher than $1^{\circ}\text{C}$ , the error code disappears.
E29	Secondary Anti-freezing Protection	Ambient temp. $\leq 0^{\circ}\text{C}$ , water inlet $\leq 2^{\circ}\text{C}$	It is the protection in winter. Once the water temperature up to $15^{\circ}\text{C}$ or the ambient temp is higher than $1^{\circ}\text{C}$ , the error code disappears.
E032	Flow Switch Protection	Flow switch is open	<ol style="list-style-type: none"> <li>1. Detect the connection of cables.</li> <li>2. Detect the flow switch.</li> <li>3. Detect the water valve is opened or opened fully.</li> <li>4. Detect the water pump and the filter.</li> <li>5. Maybe there is some air in the water route.</li> </ol>
E051	Compressor Overcurrent Shutdown Fault	Compressor Overcurrent	<ol style="list-style-type: none"> <li>1. Check ambient temp. and inlet/outlet water temp.;</li> <li>2. Turn on the unit. Record and analyze the changing process of high/low pressure, discharge/suction temp., EEV step, compressor frequency and running current.</li> <li>3. If they are OK, replace a new compressor driver board.</li> </ol>
E065	High water outlet temp. protection		Check if the water flow is too low and the outlet water whether too high
E081	Communication failure between PCB and fan drive board	Communication error between PCB and fan drive board	<ol style="list-style-type: none"> <li>1. Check the connection between PCB and fan board. All of 12V-12V, GND-GND, A-A, B-B should be closed;</li> <li>2. If they are closed, turn on the power, then measure the voltage between 12V and GND on fan board, if higher than 15V or lower than 7V, replace a new fan board.</li> </ol>

E103	Fan motor overload protection		<ol style="list-style-type: none"> <li>1. Check if the fan motor running well.</li> <li>2. Detect the current of fan motor.</li> <li>3. If the current is more than 1A, it means the motor have problem and need to replace a new one.</li> <li>4. If the current is less than 1A, it means the motor control module have problem and nee to replace a new one.</li> </ol>
E171	Anti-freezing Protection	inlet water $\leq$ A04 $^{\circ}$ C and the antifreeze temp $\leq$ A04-A05 $^{\circ}$ C	<ol style="list-style-type: none"> <li>1. Check the water flow.</li> <li>2. Check the outlet water temp sensor.</li> <li>3. Measure the ambient temp.</li> <li>4. Detect the connection of cables.</li> <li>5. Check the record of defrosting, whether the defrosting time is too long or too often.</li> </ol>
F01	Compressor activation failure		<p>Restart the unit.</p> <ol style="list-style-type: none"> <li>1. Check the changing process of EEV step, high pressure, low pressure, inlet/outlet water temp.</li> <li>2. Check the connection of U/V/W between compressor and compressor driver board.</li> <li>3. Check the compressor resistance.</li> <li>4. Check compressor driver board.</li> </ol>
F03	PFC Fault		<p>Restart the unit.</p> <ol style="list-style-type: none"> <li>1. Check the power supply connection and voltage supply is stable or not.</li> <li>2. Replace a new compressor driver board.</li> </ol>
F05	DC Bus Overvoltage		<ol style="list-style-type: none"> <li>1. Check the voltage between DCP-IN and DCN-IN, if lower than 300V, the unit will get this protection.</li> <li>2. Check the input voltage of R/S/T on compressor driver board, if lower than 210V, the unit will get this protection</li> <li>3. If they are OK, please replace a new compressor driver board.</li> </ol>
F06	DC Bus Undervoltage		<ol style="list-style-type: none"> <li>1. Check the voltage between DCP-IN and DCN-IN, if lower than 300V, it will get this protection;</li> <li>2. Check the input voltage of R/S/T on compressor driver board, if lower than 210V, it will get this protection;</li> <li>3. If they are OK, please replace a new compressor driver board</li> </ol>
F07	AC Input Undervoltage		<ol style="list-style-type: none"> <li>1. Measure the input voltage of R/S/T of driver board, if lower than 300V, it will get this protection.</li> <li>2. If it's OK, replace a new compressor driver board.</li> </ol>
F08	AC Input Overcurrent		Only in single phase unit. Restart the unit. Check if there is electric leakage. If not, replace a new drive board.
F09	Input voltage sampling fault		<ol style="list-style-type: none"> <li>1. Make sure power supply not lower than 300V or higher than 500V;</li> <li>2. If it's OK, please replace a new compressor driver board.</li> </ol>
F10	Communication Failure between DSP and PFC		<p>Only in single phase unit.</p> <ol style="list-style-type: none"> <li>1. Check the inverter board connection.</li> <li>2. If no problem, replace a new compressor driver board.</li> </ol>
F11	Communication Fault between DSP and Communication board		<ol style="list-style-type: none"> <li>1. Please check the inverter board connection.</li> <li>2. If no problem, please replace a new compressor driver board</li> </ol>
F12	Communication failure between PCB and driver board		<ol style="list-style-type: none"> <li>1. Check the connection between main control board and compressor driver board. All of 12V-12V, GND-GND, A-A, B-B should be closed.</li> <li>2. If they are closed, turn on the power, then measure the voltage between 12V and GND on compressor driver board, if higher than 15V or lower than 7V, please replace a new one compressor driver board.</li> </ol>

F13	IPM Overheat Stop		<ol style="list-style-type: none"> <li>1. Check the fans are running or not.</li> <li>2. Check the installation distance and space.</li> <li>3. Leave enough distance and space to make heat pump have a good transfer heating condition.</li> <li>4. Clean the finned heat exchanger.</li> <li>5. If they are OK, replace a new compressor driver board.</li> </ol>
F15	Input voltage Lacking Phase		<ol style="list-style-type: none"> <li>1. Check the phase of power supply R/S/T to compressor driver board.</li> <li>2. If it's OK, replace a new compressor driver board.</li> </ol>
F16	Compressor weak magnetic protection alarm		<ol style="list-style-type: none"> <li>1. Check the refrigeration system.</li> <li>2. If it's OK, replace a new compressor driver board.</li> </ol>
F17	Temperature fault of drive board		<ol style="list-style-type: none"> <li>1. Check the connection of heat sink temp. sensor.</li> <li>2. Check the resistance of heat sink temp. sensor.</li> <li>3. If they are OK, please replace a new heat sink and heat sink temp. sensor.</li> </ol>
F18	IPM Current Sampling Fault		<ol style="list-style-type: none"> <li>1. Check ambient temp. and inlet/outlet water temp.</li> <li>2. Check high/low pressure and discharge temp. and suction temp.</li> <li>3. Check EEV step.</li> <li>4. Check the compressor frequency and current.</li> <li>5. If they are OK, replace a new compressor driver board.</li> </ol>
F20	IGBT Power Device Overheat Alarm		<ol style="list-style-type: none"> <li>1. Check the fans are running or not.</li> <li>2. Check the installation distance and space.</li> <li>3. If they are OK, please replace a new compressor driver board.</li> <li>4. Leave enough distance and space to make heat pump have a good transfer heating condition.</li> <li>5. Clean air to fin heat exchanger.</li> </ol>
F22	AC input overcurrent protection alarm		<p>Only in single phase unit. Restart the unit.</p> <ol style="list-style-type: none"> <li>1. Check if there is electric leakage.</li> <li>2. If still have the failure, replace a new drive board.</li> </ol>
F23	EEPROM Fault Alarm		<ol style="list-style-type: none"> <li>1. Check the connection;</li> </ol>
F24	Destroyed EEPROM Activation Ban Alarm		<ol style="list-style-type: none"> <li>2. Replace a new driver board;</li> </ol>
F25	LP 15V Underload Fault		<ol style="list-style-type: none"> <li>1. Check the power supply is stable or not, and restart unit.</li> <li>2. If the problem still on, please replace a new drive board.</li> </ol>
F26	IGBT Power Device Overheat Fault		<ol style="list-style-type: none"> <li>1. Check the fans are running or not ;</li> <li>2. Check the installation distance and space;</li> <li>3. Leave enough distance and space to make heat pump have a good transfer heating condition;</li> <li>4. Clean the finned heat exchanger.</li> <li>5. If they are OK, please replace a new driver board;</li> </ol>
F031	DC Fan Motor 1 Failure		<ol style="list-style-type: none"> <li>1. Turn off the unit and check the connection.</li> </ol>
F032	DC Fan Motor 2 Failure		<ol style="list-style-type: none"> <li>2. Restart and check if the motor is running normal or the error happens again.</li> <li>3. Replace a new fan motor.</li> </ol>

Pp1	Exhaust Pressure Sensor Fault		<ol style="list-style-type: none"> <li>1. Detect the exhaust pressure sensor connection</li> <li>2. If the connection is OK, please replace a new one.</li> </ol>
Pp2	Suction Pressure Sensor Fault		<ol style="list-style-type: none"> <li>1. Detect the suction pressure sensor connection</li> <li>2. If the connection is OK, please replace a new one.</li> </ol>
TP	Low Ambient Temp. Protection	Ambient temp $\leq$ -30	<ol style="list-style-type: none"> <li>1 Check the ambient temp</li> <li>2. When ambient temp <math>\geq</math>-28°C , the fault will disappear.</li> </ol>
P01	Water Inlet Temp. Sensor Fault		<ol style="list-style-type: none"> <li>1. Detect the connection.</li> <li>2. Measure the resistance of sensor, if lower than 100Ω or higher than 500kΩ, please replace a new one.</li> </ol>
P02	Water Outlet Temp. Sensor Fault		
P04	Ambient Temp. Sensor Fault		
P17	Water Outlet Temp. Sensor Fault		
P032	Hot Water Tank Temp. Sensor Fault		
P42	Room Temp. Sensor Fault		
P101	EVI Inlet Temp. Sensor Fault		
P102	EVI Outlet Temp. Sensor Fault		
P153	Coil Temp. Sensor Fault		
P181	Exhaust Temp. Sensor Fault		
P182	Exhaust Over Temp.	(Exhaust temp.) $\geq$ C05 default 110	<ol style="list-style-type: none"> <li>1. Measure the resistance of sensor, if lower than 100Ω or higher than 500kΩ, please replace a new one.</li> <li>2. Check the unit find if it has refrigerant leakage.</li> </ol>
P191	Antifreeze Temp. Sensor Fault		<ol style="list-style-type: none"> <li>1. Detect the connection</li> <li>2. Measure the resistance of sensor, if lower than 100Ω or higher than 500kΩ, please replace a new one.</li> </ol>